

YASKAWA AC Drive 1000-Series Option **PROFINET** Technical Manual

Type: SI-EP3

To properly use the product, read this manual thoroughly and retain for easy reference, inspection, and maintenance. Ensure the end user receives this manual.

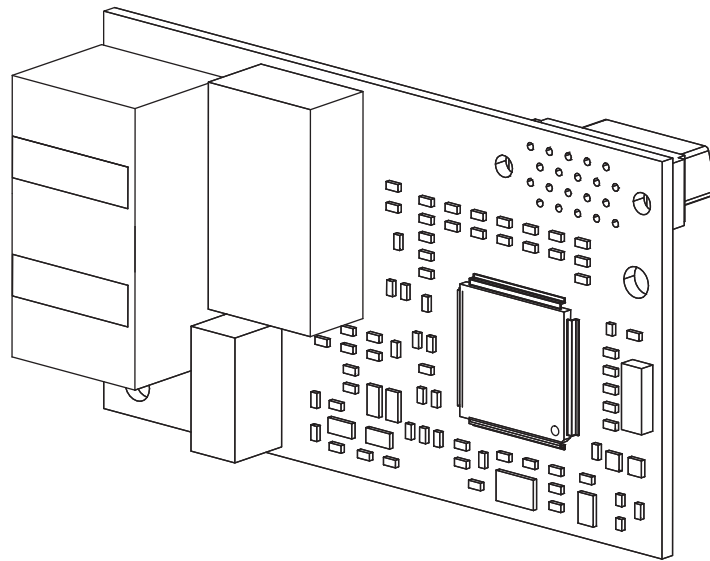



Table of Contents

| | | |
|----|---------------------------------------|----|
| 1 | PREFACE AND SAFETY | 4 |
| 2 | PRODUCT OVERVIEW | 6 |
| 3 | RECEIVING | 7 |
| 4 | OPTION COMPONENTS | 8 |
| 5 | INSTALLATION PROCEDURE | 11 |
| 6 | OPTION RELATED DRIVE PARAMETERS | 19 |
| 7 | PROFINET MESSAGING | 21 |
| 8 | COMMUNICATION | 25 |
| 9 | WEB INTERFACE | 39 |
| 10 | TROUBLESHOOTING | 46 |
| 11 | SPECIFICATIONS | 50 |

Copyright © 2011 YASKAWA AMERICA, INC.

All rights reserved. No part of this publication may be reproduced, stored in a retrieval system, or transmitted, in any form or by any means, mechanical, electronic, photocopying, recording, or otherwise, without the prior written permission of Yaskawa. No patent liability is assumed with respect to the use of the information contained herein. Moreover, because Yaskawa is constantly striving to improve its high-quality products, the information contained in this manual is subject to change without notice. Every precaution has been taken in the preparation of this manual. Yaskawa assumes no responsibility for errors or omissions. Neither is any liability assumed for damages resulting from the use of the information contained in this publication.

1 Preface and Safety

Yaskawa manufactures products used as components in a wide variety of industrial systems and equipment. The selection and application of Yaskawa products remain the responsibility of the equipment manufacturer or end user. Yaskawa accepts no responsibility for the way its products are incorporated into the final system design. Under no circumstances should any Yaskawa product be incorporated into any product or design as the exclusive or sole safety control. Without exception, all controls should be designed to detect faults dynamically and fail safely under all circumstances. All systems or equipment designed to incorporate a product manufactured by Yaskawa must be supplied to the end user with appropriate warnings and instructions as to the safe use and operation of that part. Any warnings provided by Yaskawa must be promptly provided to the end user. Yaskawa offers an express warranty only as to the quality of its products in conforming to standards and specifications published in the Yaskawa manual. **NO OTHER WARRANTY, EXPRESS OR IMPLIED, IS OFFERED.** Yaskawa assumes no liability for any personal injury, property damage, losses, or claims arising from misapplication of its products.

◆ Applicable Documentation

The following manuals are available for the SI-EP3 option:

SI-EP3 Option

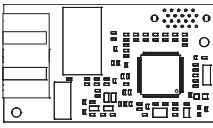
| | | |
|--|--|---|
|  | <p>Yaskawa AC Drive 1000-Series Option SI-EP3 PROFINET Installation Manual Manual No: TOEP YEACOM 07□</p> | <p>Read this manual first. The installation manual is packaged with the SI-EP3 option and contains information required to install the option and set up related drive parameters.</p> |
| | <p>Yaskawa AC Drive 1000-Series Option SI-EP3 PROFINET Technical Manual Manual No: SIEP YEACOM 07□</p> | <p>The technical manual contains detailed information about the option. In the U.S., access http://www.yaskawa.com to obtain the technical manual. Customers in other areas should contact a Yaskawa representative.</p> |

Yaskawa Drive

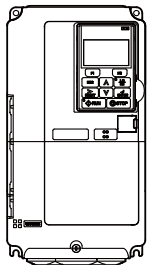
| | | |
|---|--|---|
|  | <p>Yaskawa AC Drive 1000-Series Quick Start Guide</p> | <p>The drive manuals cover basic installation, wiring, operation procedures, functions, troubleshooting, and maintenance information. The manuals also include important information about parameter settings and drive tuning. Access these sites to obtain Yaskawa instruction manuals: U.S.: http://www.yaskawa.com Europe: http://www.yaskawa.eu.com Japan: http://www.e-mechatronics.com Other areas: contact a Yaskawa representative.</p> |
| | <p>Yaskawa AC Drive 1000-Series Technical Manual</p> | |

◆ Terms

Note: Indicates supplemental information that is not related to safety messages.

Drive: Yaskawa AC Drive 1000-Series

Option: Yaskawa AC Drive 1000-Series SI-EP3 PROFINET option

◆ Registered Trademarks

- All trademarks are the property of their respective owners.

◆ Supplemental Safety Information

Read and understand this manual before installing, operating, or servicing this option. The option must be installed according to this manual and local codes.

The following conventions are used to indicate safety messages in this manual. Failure to heed these messages could result in serious or possibly even fatal injury or damage to the products or to related equipment and systems.

DANGER

Indicates a hazardous situation, which, if not avoided, will result in death or serious injury.

WARNING

Indicates a hazardous situation, which, if not avoided, could result in death or serious injury.

CAUTION

Indicates a hazardous situation, which, if not avoided, could result in minor or moderate injury.

NOTICE

Indicates an equipment damage message.

■ General Safety

General Precautions

- The diagrams in this section may include options and drives without covers or safety shields to illustrate details. Reinstall covers or shields before operating any devices. The option should be used according to the instructions described in this manual.
- Any illustrations, photographs, or examples used in this manual are provided as examples only and may not apply to all products to which this manual is applicable.
- The products and specifications described in this manual or the content and presentation of the manual may be changed without notice to improve the product and/or the manual.
- When ordering new copies of the manual, contact a Yaskawa representative or the nearest Yaskawa sales office and provide the manual number shown on the front cover.

DANGER

Heed the safety messages in this manual.

Failure to comply will result in death or serious injury.

The operator is responsible for injuries or equipment damage caused from failure to heed the warnings in the manual.

NOTICE

Do not expose the drive to halogen group disinfectants.

Failure to comply may cause damage to the electrical components in the option.

Do not pack the drive in wooden materials that have been fumigated or sterilized.

Do not sterilize the entire package after the product is packed.

Do not modify the drive or option circuitry.

Failure to comply could result in damage to the drive or option and will void warranty.

Yaskawa is not responsible for any modification of the product made by the user. This product must not be modified.

2 Product Overview

◆ About This Product

The SI-EP3 option connects the 1000-series drives to a PROFINET network and facilitates the exchange of data.

This manual explains the handling, installation and specifications of this product.

The SI-EP3 option is a simple, networking solution that reduces the cost and time to wire and install factory automation devices, while providing interchangeability of like components from multiple vendors.

By installing the option to a drive, it is possible to do the following from a PROFINET master device:

- Operate the drive
- Monitor the operation status of the drive
- Change parameter settings.

SI-EP3 is PROFINET Conformance Class A certified.

◆ Applicable Models

The option can be used with the drive models in *Table 1*.

Table 1 Applicable Models

| Drive Series | Drive Model Number | Software Version <1> |
|--------------|--------------------|------------------------|
| A1000 | CIMR-A□2A□□□□ | VSA90101□ |
| | CIMR-A□4A□□□□ | |
| | CIMR-A□5A□□□□ | VSA90504□ VSA90101□ |
| | CIMR-A□4A0930~1200 | VSA903014 and greater |





<1> See “PRG” on the drive nameplate for the software version number.

3 Receiving

Please perform the following tasks upon receipt of the option:

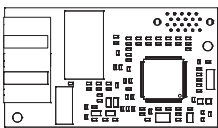
- Inspect the option for damage. Contact the shipper immediately if the option appears damaged upon receipt.
- Verify receipt of the correct model by checking the model number printed on the name plate of the option package.
- Contact your supplier if you have received the wrong model or the option does not function properly.

◆ Option Package Components

| Description: | Option | Ground Wire | Screws (M3) | LED Label | Installation Manual |
|------------------|---|---|---|---|---|
| — |  |  |  |  |  |
| Quantity: | 1 | 1 | 3 | 1 | 1 |

◆ Tools Required for Installation

- A Phillips screwdriver (M3 metric/#1, #2 U.S. standard size*) is required to install the option and remove drive front covers.
- Diagonal cutting pliers. (required for some drive models)
- A small file or medium grit sandpaper. (required for some drive models)

*Screw sizes vary by drive capacity. Select a screwdriver appropriate for the drive capacity.

Note: Tools required to prepare option networking cables for wiring are not listed in this manual.

4 Option Components

◆ SI-EP3 PROFINET Option

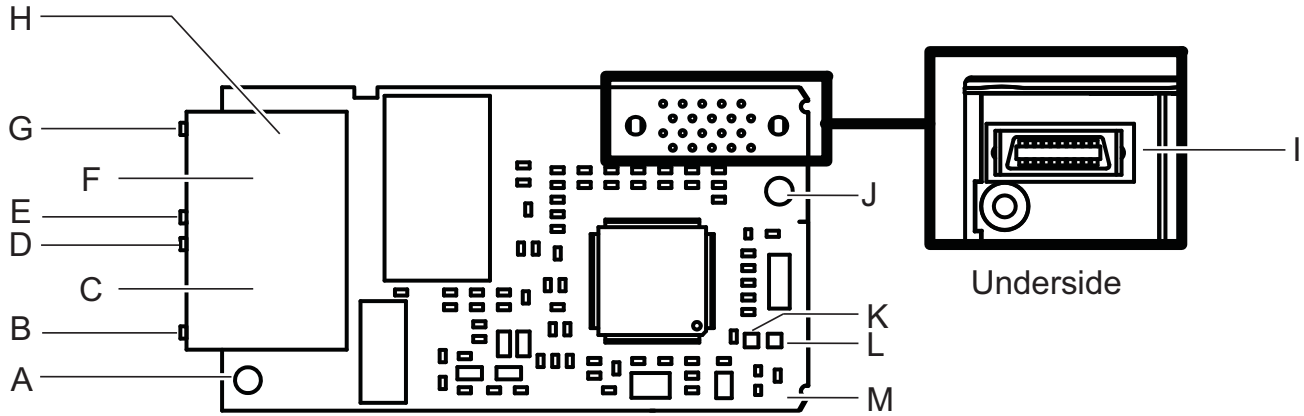

- | | |
|---|-------------------------------|
| A – Ground Terminal and installation hole <1> | H – PROFINET cable connection |
| B – Port 1 LED (10/100) <2> | I – Option connector |
| C – Port 1 | J – Installation hole |
| D – Port 1 LED (LINK/ACT) <2> | K – LED (NS) <2> |
| E – Port 2 LED (10/100) <2> | L – LED (MS) <2> |
| F – Port 2 | M – PROFINET PCB |
| G – Port 2 LED (LINK/ACT) <2> | |

<1> The ground wire provided in the option shipping package must be connected during installation
 <2> Refer to Option LED Display on page 9 for details on the LEDs

Figure 1 Option (Top View)

◆ Terminal CN1

The communication connector on the option is a modular RJ45 female connector designated CN1. CN1 is the connection point for a customer supplied male Ethernet network communication cable.

Table 2 Male, 8-way Ethernet Modular Connector (Customer Supplied)

| Male Ethernet 8-Way Modular Connector | Pin | Description |
|---------------------------------------|------------|-----------------------|
| | 1 (Pair 2) | Transmit data (TXD) + |
| | 2 (Pair 2) | Transmit data (TXD) - |
| | 3 (Pair 3) | Receive data (RXD) + |
| | 4 (Pair 1) | Not used <1> |
| | 5 (Pair 1) | Not used <1> |
| | 6 (Pair 3) | Receive data (RXD) - |
| | 7 (Pair 4) | Not used <1> |
| | 8 (Pair 4) | Not used <1> |

<1> Not used for 10 Mbps and 100 Mbps networks.

◆ Option LED Display

The option has six LEDs:

Bi-color Status LEDs:

- Module status (MS) red/green
- Network status (NS) red/green

PROFINET LEDs:

- Network speed-10/100 yellow
- Link status and network activity-Link/Act green

The operational states of the option LEDs after the power-up diagnostic LED sequence is completed are described in [Table 3](#). The states with a number in parenthesis are the number of pulses of 250 ms on, 250 ms off cycles, followed by 500 ms off, then repeating the cycle. Wait at least 2 seconds for the power-up diagnostic process to complete before verifying LED states.

Table 3 Option LED States

| Name | Indication | | Operating Status | Remarks |
|--|------------|--------------|---|--|
| | Color | Status | | |
| MS (visible through drive cover) | – | OFF | Power supply OFF | Power is not being supplied to the drive. |
| | Green | ON | Option operating | The option is operating normally and initialization is complete. |
| | Green | Flashing (1) | Diagnostics | Diagnostic data available. |
| | Green | Flashing (2) | Configuration tool | Identified by a configuration tool. |
| | Red | ON | Default MAC or fatal error occurred. | Default MAC address has been programmed or the option has detected an unrecoverable error. |
| | Red | Flashing (1) | Configuration error (non-fatal) | Configuration error. |
| | Red | Flashing (2) | No IP (non-fatal) | No IP address assigned. |
| | Red | Flashing (3) | No station name (non-fatal) | No station name assigned. |
| | Red | Flashing (4) | Init failure (non-fatal) | Failed to initialize module. |
| | Green/Red | Flashing | Option self-test | The option is in self-test mode. |
| NS (visible through drive cover) | – | OFF | Offline or Power supply OFF | – |
| | Green | ON | Connected | Connection established with I/O controller and in RUN mode. |
| | Green | Flashing | Connected and stopped | Connection established with I/O controller and in STOP mode. |
| | Red | ON | BUS fault | Unrecoverable BUS fault. |
| | Red | Flashing (1) | Lost communication | Host communication is temporarily lost. |
| | Red | Flashing (2) | Lost link | No link detected to network. |
| 10/100 (visible at RJ45 jack) | Yellow | OFF | 10 Mbps is established | – |
| | Yellow | ON | 100 Mbps is established | – |
| LINK/ACT (visible at RJ45 jack) | Green | OFF | Link is not established | – |
| | Green | ON | Link is established | – |
| | Green | Flashing | Link is established and there is network activity | – |

4 Option Components

■ Power-Up Diagnostics

An LED test is performed each time the drive is powered up. The initial boot sequence may take several seconds. After the LEDs have completed the diagnostic LED sequence, the option is successfully initialized. The LEDs then assume operational conditions as shown in [Table 3](#).

Table 4 Power-Up Diagnostic LED Sequence

| Sequence | Module Status (MS) | Network Status (NS) | Time (ms) |
|----------|--------------------|---------------------|-----------|
| 1 | Green | OFF | 250 |
| 2 | Red | OFF | 250 |
| 3 | Green | OFF | - |
| 4 | Green | Green | 250 |
| 5 | Green | Red | 250 |
| 6 | Green | OFF | - |

5 Installation Procedure

◆ Section Safety

DANGER

Electrical Shock Hazard

Do not connect or disconnect wiring while the power is on.

Failure to comply will result in death or serious injury.

Disconnect all power to the drive, wait at least five minutes after all indicators are off, measure the DC bus voltage to confirm safe level, and check for unsafe voltages before servicing. The internal capacitor remains charged after the power supply is turned off. The charge indicator LED will extinguish when the DC bus voltage is below 50 Vdc.

WARNING

Electrical Shock Hazard

Do not remove the option cover while the power is on.

Failure to comply could result in death or serious injury.

The diagrams in this section may include options and drives without covers or safety shields to show details. Be sure to reinstall covers or shields before operating any devices. Use the option according to the instructions described in this manual.

Do not allow unqualified personnel to use equipment.

Failure to comply could result in death or serious injury.

Maintenance, inspection, and replacement of parts must be performed only by authorized personnel familiar with installation, adjustment, and maintenance of this product.

Do not touch circuit boards while the power to the drive is on.

Failure to comply could result in death or serious injury.

Do not use damaged wires, stress the wiring, or damage the wire insulation.

Failure to comply could result in death or serious injury.

Fire Hazard

Tighten all terminal screws to the specified tightening torque.

Loose electrical connections could result in death or serious injury by fire due to overheating of electrical connections.

NOTICE

Damage to Equipment

Observe proper electrostatic discharge (ESD) procedures when handling the option, drive, and circuit boards.

Failure to comply may result in ESD damage to circuitry.

Never shut the power off while the drive is running or outputting voltage.

Failure to comply may cause the application to operate incorrectly or damage the drive.

Do not operate damaged equipment.

Failure to comply may cause further damage to the equipment.

Do not connect or operate any equipment with visible damage or missing parts.

NOTICE

Do not use unshielded cable for control wiring.

Failure to comply may cause electrical interference resulting in poor system performance.

Use shielded twisted-pair wires and ground the shield to the ground terminal of the drive.

Properly connect all pins and connectors.

Failure to comply may prevent proper operation and possibly damage equipment.

Check wiring to ensure that all connections are correct after installing the option and connecting any other devices.

Failure to comply may result in damage to the option.

◆ Prior to Installing the Option

Prior to installing the option, wire the drive, make necessary connections to the drive terminals, and verify that the drive functions normally without the option installed. Refer to the Quick Start Guide packaged with the drive for information on wiring and connecting the drive.

Figure 2 shows an exploded view of the drive with the option and related components for reference.

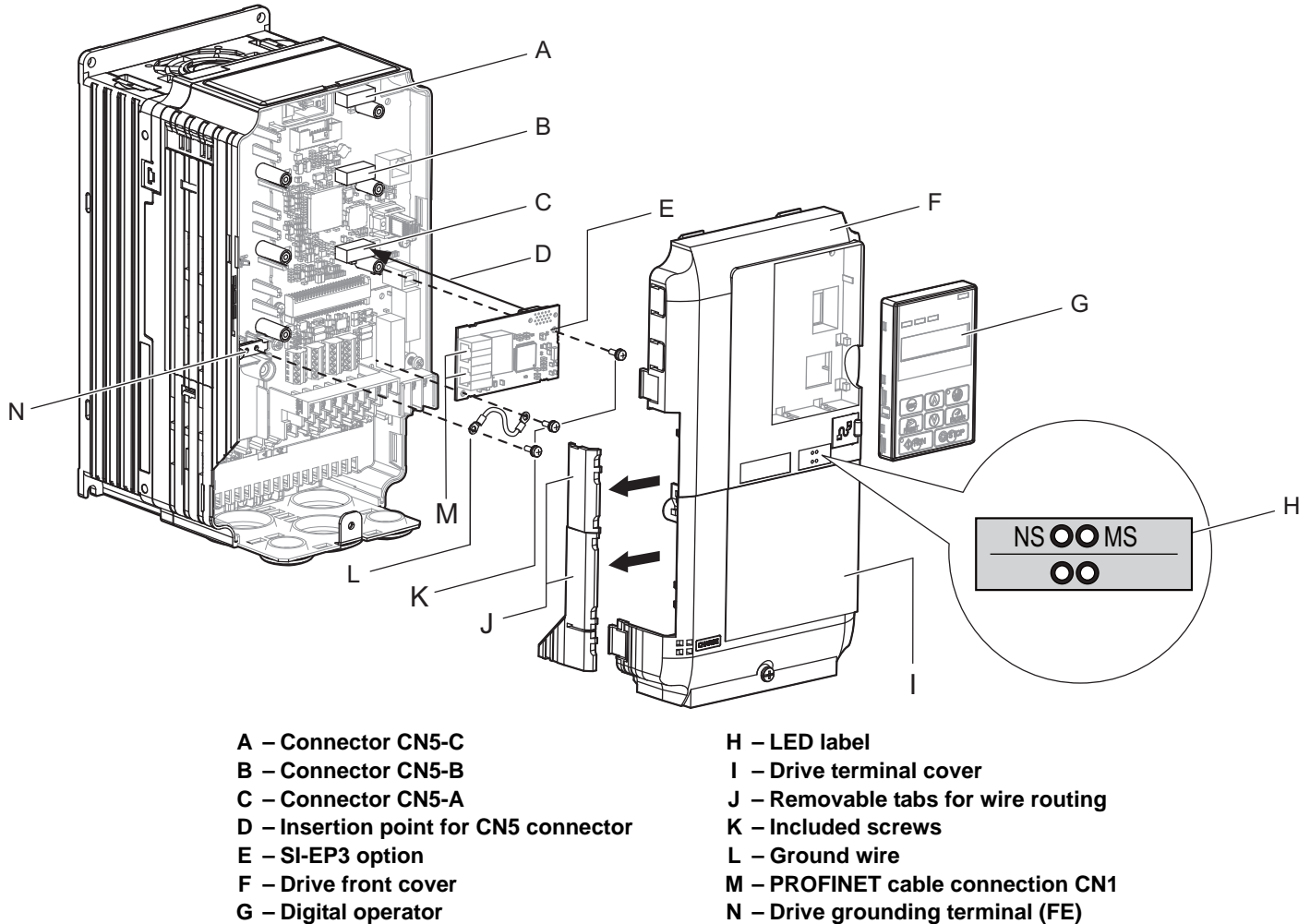

Figure 2 Drive Components with Option

◆ Installing the Option

Remove the front covers of the drive before installing the option. Refer to the drive Quick Start Guide for directions on removing the front covers. Cover removal varies depending on drive size. This option can be inserted only into the CN5-A connector located on the drive control board.

1. Shut off power to the drive, wait the appropriate amount of time for voltage to dissipate, then remove the digital operator (G) and front covers (F, I). Front cover removal varies by model.

DANGER! *Electrical Shock Hazard. Do not connect or disconnect wiring while the power is on. Failure to comply will result in death or serious injury. Before installing the option, disconnect all power to the drive. The internal capacitor remains charged even after the power supply is turned off. The charge indicator LED will extinguish when the DC bus voltage is below 50 Vdc. To prevent electric shock, wait at least five minutes after all indicators are off and measure the DC bus voltage level to confirm safe level.*

NOTICE: *Damage to Equipment. Observe proper electrostatic discharge procedures (ESD) when handling the option, drive, and circuit boards. Failure to comply may result in ESD damage to circuitry.*

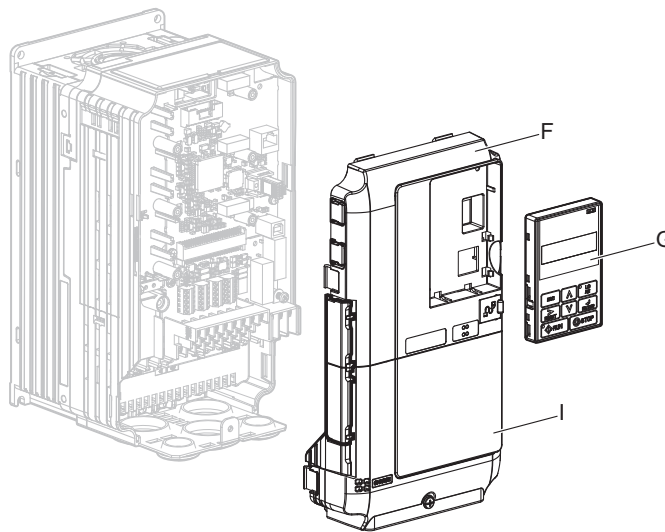

Figure 3 Remove the Front Covers and Digital Operator

2. With the front covers and digital operator removed, apply the LED label (H) in the appropriate position on the drive top front cover (F).

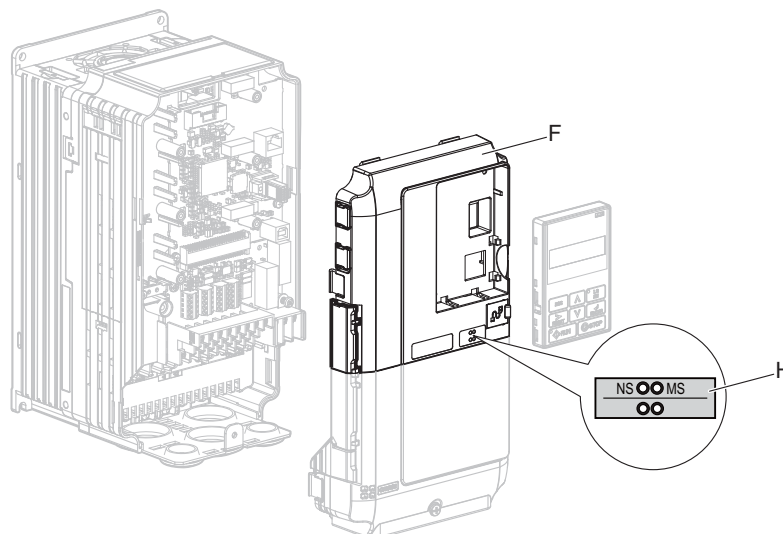

Figure 4 Apply the LED Label

3. Insert the option (E) into the **CN5-A** connector (C) located on the drive and fasten it using one of the included screws (K).

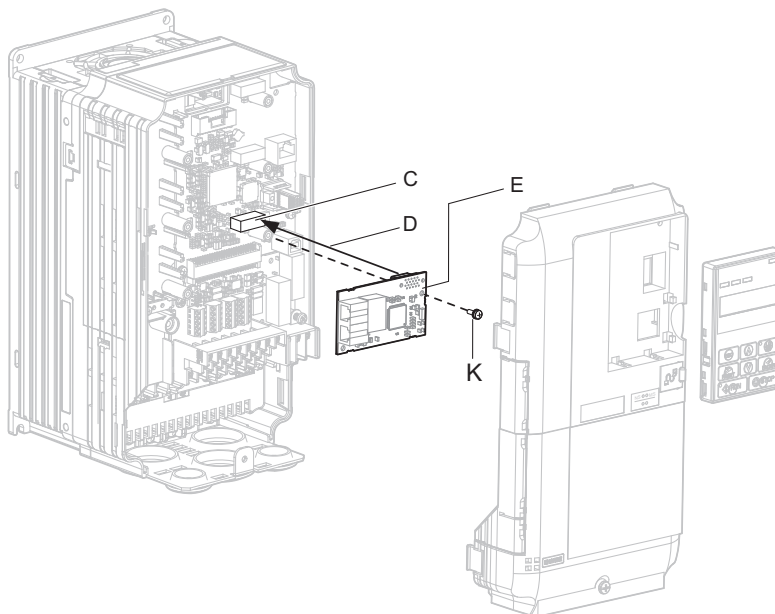

Figure 5 Insert the Option

4. Connect the ground wire (L) to the ground terminal (N) using one of the remaining provided screws (K). Connect the other end of the ground wire (L) to the remaining ground terminal and installation hole on the option (E) using the last remaining provided screw (K) and tighten both screws to 0.5 ~ 0.6 nm or (4.4 ~ 5.3 in lbs).

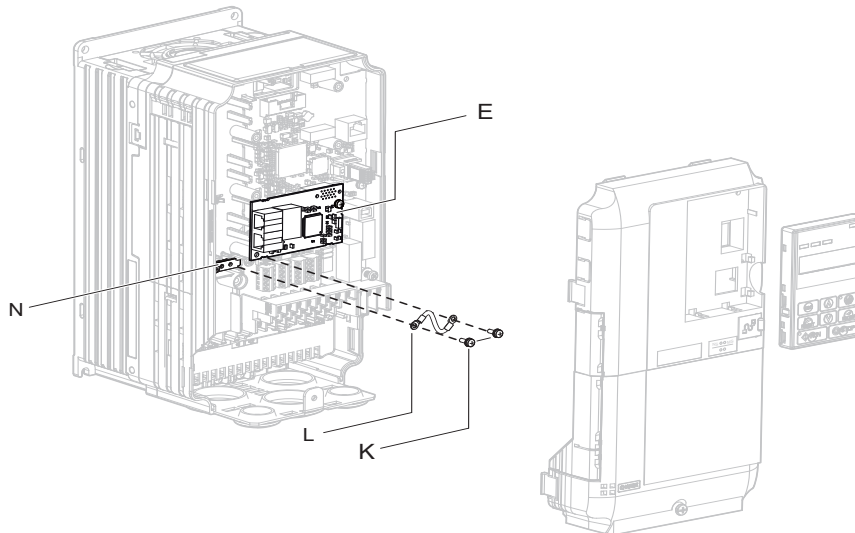

Figure 6 Connect the Ground Wire

Note: There are two screw holes on the drive for use as ground terminals. When connecting three options, two ground wires will need to share the same drive ground terminal.

5 Installation Procedure

■ Wiring the Option

5. Route the option wiring.

Depending on the drive model, some drives may require routing the wiring through the side of the front cover to the outside to provide adequate space for the wiring. In these cases, using diagonal cutting pliers, cut out the perforated openings on the left side of the drive front cover. Sharp edges along the cut out should be smoothed down with a file or sand paper to prevent any damage to the wires.

5.a Route the PROFINET Cat 5e cable inside the enclosure for drives that do not require routing through the front cover. Refer to [Table 5](#) and [Figure 7](#) to determine the proper wire routing by drive model.

Table 5 Model-Specific Cable Routing

| Drive Series | Model | Wire Routing <1> | |
|--------------|--|------------------------------|------------------------------|
| | | Through Front Cover | Inside Drive |
| A1000 | CIMR-A□2A0004 to 0040; CIMR-A□4A0002 to 0023; CIMR-A□5A0003 to 0011 | Figure 7 (A) | - |
| A1000 | CIMR-A□2A0056 and above; CIMR-A□4A0031 and above; CIMR-A□5A0023 and above. | - | Figure 7 (B) |

<1> Refer to [Figure 7](#) for examples of the different wire routing techniques.

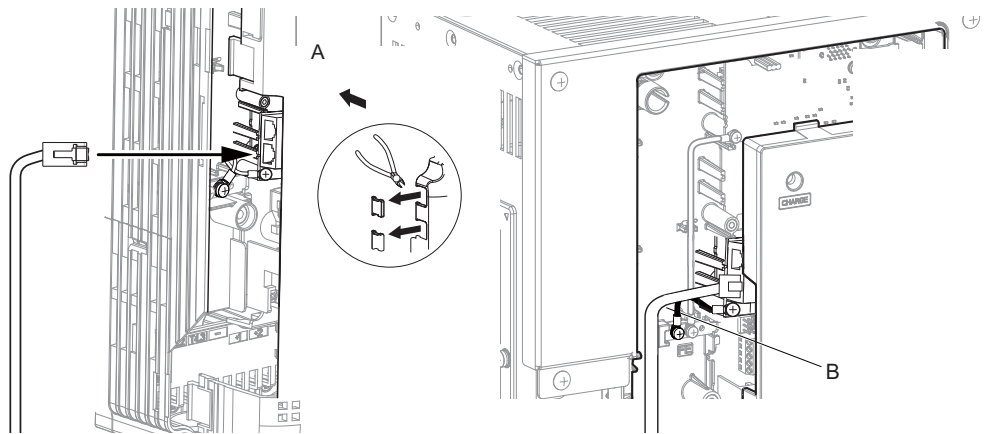

A – Route wires through the openings provided on the left side of the front cover. <1>

B – Use the open space provided inside the drive to route option wiring.

<1> The drive will not meet NEMA Type 1 requirements if wiring is exposed outside the enclosure.

Figure 7 Wire Routing Examples

6. Connect the PROFINET Cat 5e communication cable to the option connector (CN1) port 1. To connect the option to a network, firmly connect RJ45 8-pin Shielded Twisted Pair Cat 5e cable(s) into the modular connector ports (see [Figure 7](#)).

Note: Do not connect or disconnect the communication cable while the drive is powered up or while the drive is in operation. Failure to comply may cause a static discharge, which will cause the option card to stop working properly. Cycle power on the drive and option card to reestablish functionality.

■ Communication Cable Wiring

The dual RJ45 network ports on the option board act as a switch to allow for flexibility in cabling topology. For example, a traditional star network topology may be employed by using a single port on the option board. Alternatively, a daisy-chained approach may be employed by using both RJ45 ports. This second approach reduces the requirements of central switch ports.

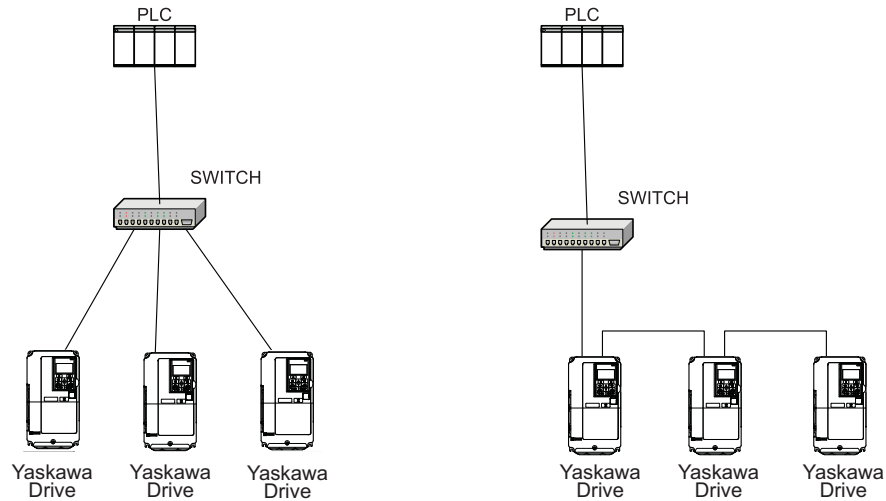

Figure 8 Topology Options

Communication Cable Specifications

Only use cables recommended for PROFINET. Using a cable not specifically recommended may cause the option or drive to malfunction.

The use of CAT5e or equivalent Shielded Twisted Pair (STP) cable is recommended.

7. Use the second communication cable port to daisy chain a series of drives where applicable.

■ Connection Diagram

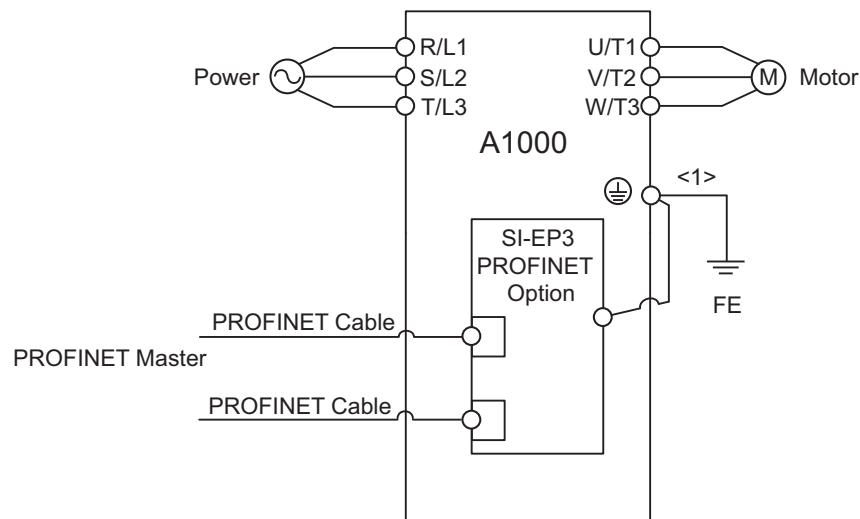

<1> The ground wire provided in the option shipping package must be connected during installation.

Figure 9 Wiring Diagram

5 Installation Procedure

8. Replace and secure the front covers of the drive (F, I) and replace the digital operator (G).

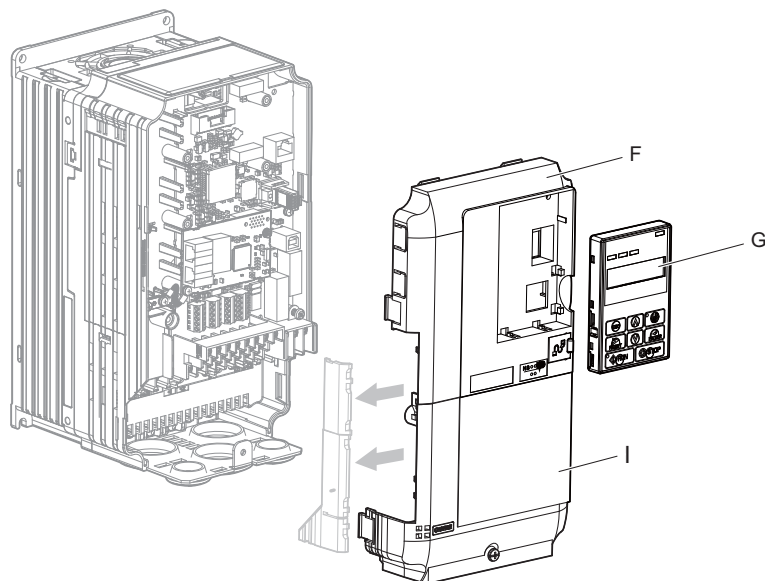

Figure 10 Replace the Front Covers and Digital Operator

Note: Take proper precautions when wiring the option so that the front covers will easily fit back onto the drive. Make sure no cables are pinched between the front covers and the drive when replacing the covers.

9. Set drive parameters in [Table 6](#) for proper option performance.

◆ GSD Files

For easy network implementation of drives equipped with the SI-EP3 option, a GSD file can be obtained from:

U.S.: <http://www.yaskawa.com>

Other areas: Contact a Yaskawa representative.

6 Option Related Drive Parameters

The following parameters are used to set up the drive for operation with the option. Parameter setting instructions can be found in the drive Quick Start Guide or Technical Manual.

Confirm proper setting of the all parameters in [Table 6](#) before starting network communications.

Table 6 Parameter Settings

| No. | Name | Description | Default |
|----------------|--|---|------------------------------|
| b1-01 <1> | Frequency Reference Selection | Selects the frequency reference input source. 0: Operator - Digital preset speed d1-01 to d1-17 1: Terminals - Analog input terminal A1 or A2 2: MEMOBUS/Modbus communications 3: Option PCB 4: Pulse Input (Terminal RP) | 1 (Set to 3 for PROFINET) |
| b1-02 <1> | Run Command Selection | Selects the run command input source. 0: Digital Operator - RUN and STOP keys 1: Digital input terminals S1 to S7 2: MEMOBUS/Modbus communications 3: Option PCB | 1 (Set to 3 for PROFINET) |
| F6-01 | Operation Selection after Communications Error | Determines drive response when a bUS error is detected during communications with the option. 0: Ramp to Stop 1: Coast to Stop 2: Fast-Stop 3: Alarm Only <2> | 1 |
| F6-02 | External Fault Detection Conditions (EF0) | Sets the condition for external fault detection (EF0). 0: Always detected 1: Detected only during operation | 0 |
| F6-03 | Stopping Method for External Fault from Communication Option Board | Determines drive response for external fault input (EF0) detection during communication. 0: Ramp to Stop 1: Coast to Stop 2: Fast-Stop 3: Alarm Only <2> | 1 |
| F6-07 | NetRef/ComRef Selection Function | 0: Multi-step speed reference disabled 1: Multi-step speed reference allowed | 1 |
| F6-08 | Reset Communication Related Parameters | Determines if communication-related parameters F6-□□ and F7-□□ are set back to original default values when the drive is initialized using parameter A1-03. 0: Do not reset F6-□□ and F7-□□ parameters 1: Reset F6-□□ and F7-□□ parameters Note: Setting this parameter does not affect communication-related parameters. | 0 |
| F7-01 to F7-04 | IP Address | Sets static IP address of the SI-EP3 option when parameter F7-13=0. Note: Parameter F7-01 sets the most significant octet. | 192 168 1 20 |
| F7-05 to F7-08 | Subnet Mask | Sets static Subnet Mask of network connection. Note: Parameter F7-05 sets the most significant octet | 255 255 255 0 |
| F7-09 to F7-12 | Gateway Address | Sets static Gateway address of network connection. Note: Parameter F7-09 sets the most significant octet. | 192 168 1 1 |
| F7-13 | Address Mode at Startup | Selects how the option address is set. 0: Static 2: DCP | 2 |
| F7-14 | Duplex Mode Selection | Selects duplex mode setting. 0: Half duplex forced 1: Auto-negotiate duplex mode and communication speed 2: Full duplex forced | 1 |

6 Option Related Drive Parameters

| No. | Name | Description | Default |
|--------------------|---|--|---------|
| F7-15 | Communication Speed Selection | Sets the communication speed. 10: 10 Mbps 100: 100 Mbps | 10 |
| F7-23 to F7-27 <3> | Dynamic Output Assembly Parameters | Configurable outputs 1 to 5. | 0 |
| F7-33 to F7-37 <3> | Dynamic Input Assembly Parameters | Configurable inputs 1 to 5. | 0 |
| H5-11 | Communications ENTER Function Selection | Select the function for the ENTER command that saves parameter data to the drive. 0: Parameter changes are activated when ENTER command is written 1: Parameter changes are activated immediately without use of ENTER command | 1 |

- <1> To start and stop the drive with the option master device using serial communications, set b1-02 to 3. To control the drive frequency reference via the master device, set b1-01 to 3.
- <2> If F6-01 is set to 3, then the drive will continue to operate when a bUS error or an EF0 fault is detected. Take proper safety measures, such as installing an emergency stop switch.
- <3> If a value other than 0 is assigned to parameters F7-23 to F7-27 and F7-33 to F7-37 by the drive, that value will take precedent over a value set by the configuration software. If the value in the drive is 0 (default), the value from the configuration software is used.

Table 7 Option Monitors

| No. | Name | Description | Value Range |
|----------------|-------------------|---|------------------|
| U6-80 to U6-83 | Online IP Address | SI-EP3 IP Address, U6-80 is the most significant octet. | 0 to 255 |
| U6-84 to U6-87 | Online Subnet | Subnet, U6-94 is the most significant octet. | 0 to 255 |
| U6-88 to U6-91 | Online Gateway | Gateway, U6-88 is the most significant octet. | 0 to 255 |
| U6-92 | Online Speed | Port 1 Link Speed | 10, 100 |
| U6-93 | Online Duplex | Port 1 Duplex Setting | 0: Half, 1: Full |
| U6-94 | Online Duplex | Port 2 Link Speed | 0: Half, 1: Full |
| U6-95 | Online Duplex | Port 2 Duplex Setting | 0: Half, 1: Full |
| U6-98 | First Fault | First Option Board Fault | - |
| U6-99 | Current Fault | Current Option Board Fault | - |

7 PROFINET Messaging

◆ PROFINET Overview

This section describes the communication profile used between the PROFINET I/O network and the option.

The option supports the PROFIDrive profile. Users can select between the control and status words according to the PROFIDrive profile or use the Yaskawa-specific control and status words.

◆ PROFIDrive Communication Profile

■ The Control Word and the Status Word

The contents of the Control Word and the Status Word are detailed in [Table 8](#). and [Table 9](#). respectively. The drive states are presented in the PROFIDrive State Machine ([Figure 10](#)).

■ Frequency Reference

The Frequency reference is a 16-bit word containing a sign bit and a 15-bit integer. A negative reference (indicating reverse direction of rotation) is formed by calculating the two's complement from the corresponding positive reference. The reference value is the desired output frequency.

■ Output Frequency

Output Frequency is a 16-bit word containing the current output frequency (U1-02) of the drive.

Table 8 Control Word for PROFIDrive Communication Profile

| Bit | Name | Value | Proceed to STATE/Description |
|----------|-------------------|--------|--|
| 0 | ON | 1 | Proceed to READY TO OPERATE. |
| | OFF1 | 0 | Emergency OFF. Proceed to OFF1 ACTIVE; proceed further to READY TO SWITCH ON unless other interlocks (OFF2, OFF3) are active. |
| 1 | OFF2 | 1 | Continue operation (OFF2 inactive). |
| | | 0 | Emergency OFF. Proceed to OFF2 ACTIVE; proceed further to SWITCH ON INHIBIT. |
| 2 | OFF3 | 1 | Continue operation (OFF3 inactive). |
| | | 0 | Emergency stop. Proceed to OFF3 ACTIVE; proceed further to SWITCH-ON INHIBIT. |
| 3 | OPERATION_ ENABLE | 1 | Proceed to ENABLE OPERATION. |
| | | 0 | Inhibit operation. Proceed to OPERATION INHIBIT. |
| 4 | RAMP_OUT_ ZERO | 1 | Normal operation. Proceed to RAMP FUNCTION GENERATOR: ENABLE OUTPUT. |
| | | 0 | Stop according to selected stop type. |
| 5 | RAMP_HOLD | 1 | Normal operation. |
| | | 0 | Proceed to RAMP FUNCTION GENERATOR: ENABLE ACCELERATOR. Halt ramping (Ramp Function Generator output held). |
| 6 | RAMP_IN_ ZERO | 1 | Normal operation. Proceed to OPERATING. Note: This bit is effective only if the fieldbus interface is set as the source for this signal by drive parameters. |
| | | 0 | Force Ramp Function Generator input to zero. |
| 7 | RESET | 0 -> 1 | Fault reset if an active fault exists. Proceed to SWITCH ON INHIBIT. |
| | | 0 | (Continue normal operation) |
| 8 | INCHING_1 | - | Inching 1. (Not supported) |
| 9 | INCHING_2 | - | Inching 2. (Not supported) |
| 10 | REMOTE_CMD | 1 | Network control enabled. |
| | | 0 | Network control disabled. |
| 11 to 15 | - | - | Reserved |

Table 9 Status Word for the PROFIdrive Communication Profile

| Bit | Name | Value | STATE/Description |
|----------|--------------|-------|--|
| 0 | RDY_ON | 1 | READY TO SWITCH ON. |
| | | 0 | NOT READY TO SWITCH ON. |
| 1 | RDY_RUN | 1 | READY TO OPERATE. |
| | | 0 | OFF1 ACTIVE. |
| 2 | RDY_REF | 1 | ENABLE OPERATION. |
| | | 0 | DISABLE OPERATION. |
| 3 | TRIPPED | 1 | FAULT. |
| | | 0 | No fault. |
| 4 | OFF_2_STA | 1 | OFF2 inactive. |
| | | 0 | OFF2 ACTIVE. |
| 5 | OFF_3_STA | 1 | OFF3 inactive. |
| | | 0 | OFF3 ACTIVE. |
| 6 | SWC_ON_INHIB | 1 | SWITCH-ON INHIBIT ACTIVE. |
| | | 0 | SWITCH-ON INHIBIT NOT ACTIVE. |
| 7 | ALARM | 1 | Warning/Alarm. |
| | | 0 | No Warning/Alarm. |
| 8 | AT_SETPOINT | 1 | OPERATING. Actual value equals reference value (i.e., is within tolerance limits). |
| | | 0 | Actual value differs from reference value (i.e., is outside tolerance limits). |
| 9 | REMOTE | 1 | Drive control location: REMOTE. |
| | | 0 | Drive control location: LOCAL. |
| 10 | ABOVE_LIMIT | - | Not supported. |
| 11 to 15 | - | - | Reserved |

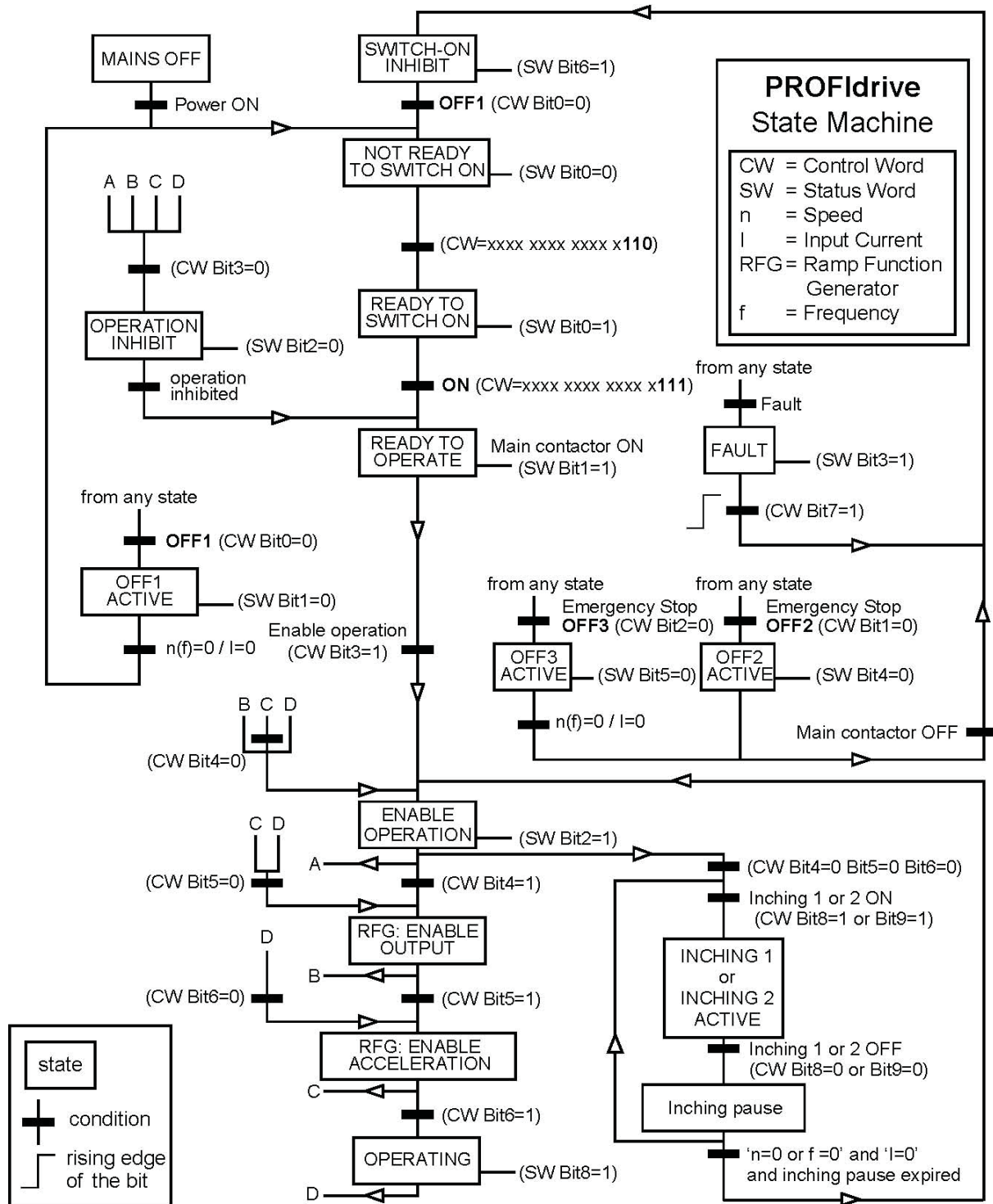

Figure 11 PROFdrive State Machine

◆ Yaskawa Vendor-Specific Control and Status Words

■ The Control Word and the Status Word

The contents of the Control Word and the Status Word are detailed in [Table 10](#).

■ Frequency Reference

Frequency Reference is a 16-bit word containing the desired output frequency.

■ Output Frequency

Output Frequency is a 16-bit word containing the current output frequency of the drive.

Table 10 Yaskawa-Specific Control Word and Status Word

| Yaskawa-Specific Control Word | | Yaskawa-Specific Status Word | |
|-------------------------------|-----------------|------------------------------|---------------------------|
| Bit | Description | Bit | Description |
| 0 | Run bit | 0 | Running |
| 1 | Reverse run bit | 1 | Zero Speed |
| 2 | EF0 | 2 | Reverse Operation |
| 3 | Fault Reset | 3 | Reset Signal Input Active |
| 4 | ComFref | 4 | At Speed |
| 5 | ComCtrl | 5 | Ready |
| 6 | DI3 | 6 | Alarm |
| 7 | DI4 | 7 | Fault |
| 8 | DI5 | 8 | oPE Fault |
| 9 | DI6 | 9 | Uv Return |
| 10 | DI7 | 10 | 2nd Motor |
| 11 | DI8 <1> | 11 | ZSV |
| 12 | DI9 <1> <2> | 12 | (Unused) |
| 13 | DI10 <1> <2> | 13 | (Unused) |
| 14 | DI11 <1> <2> | 14 | Net Reference |
| 15 | DI12 <1> <2> | 15 | Net Control |

<1> Not available in V1000-series drives.

<2> Not available in A1000-series drives.

8 Communication

This section describes the PROFINET IO messaging used in communication with the drive.

For detailed information on PROFINET IO communication, refer to PROFINET specification Application Layer protocol for decentralized periphery and distributed automation v2.0 available at www.profibus.com.

◆ Introduction to PROFINET IO

PROFINET IO is a fieldbus protocol that enables communication between programmable controllers and distributed field devices in Ethernet network. The protocol classifies devices into IO controllers, IO supervisors and IO devices, which have a specific collection of services.

PROFINET IO uses three different communication channels to exchange data. The standard UDP/IP and TCP/IP channel is used for parameterization and configuration of devices and for acyclic operations. The Real Time (RT) channel is used for cyclic data transfer and alarms. The third channel, Isochronous Real Time (IRT) channel, is used e.g. in motion control applications (not implemented in SI-EP3).

PROFINET IO devices are structured in slots and sub-slots, which can contain modules and sub-modules correspondingly. Devices can have almost any number of slots and sub-slots and they can be virtual or real. Device specific data is represented in slot 0, module and sub-module specific data in subsequent slots and sub-slots.

One of the benefits of PROFINET IO is the diagnostics and alarm mechanism. Every module and sub-module provide alarm data to the IO controller using the cyclic channel. Diagnostic data can be read non-cyclically from the device by using record data.

Properties and services of a PROFINET IO device are described in a GSD file that is written in General Station Description Markup Language (GSDML). GSD file describes the device specific modules and the method of assigning modules and sub-modules to predefined slots and sub-slots.

◆ PROFINET IO in SI-EP3

The decision to use either the PROFIdrive control and status words or the Yaskawa-specific control and status words is done in a hardware configuration tool (customer supplied). The default value is the Yaskawa-specific format.

SI-EP3 uses slots 0 and 1. Slot 0 does not have any sub-slots and the attached DAP module represents the device. Other functional modules and sub-modules described in the GSD file can be assigned to slot 1 and its sub-slots.

- Slot 0 = Device access point (DAP)
- Slot 1, sub-slot 1 = Standard telegram 1, Standard telegram 1 + 5 configurable inputs, outputs, Forty byte IO with 5 configurable input, outputs

The services provided by the SI-EP3 option can be defined using the F7-□□ parameters in the drive or by using a configuration tool. To define the service using the F7-□□ parameters, set the parameter to a value other than 0. If all F7-□□ parameters are set to 0, the value from the configuration tool will be used.

The SI-EP3 option provides the following services:

- Cyclic messaging in PROFIdrive or Yaskawa-specific mode
- Acyclic parameter access mechanism
- Identification & Maintenance functions (I&M0)
- PROFIdrive parameters
- Diagnostic and alarm mechanism
- Fault buffer mechanism

■ Yaskawa SI-EP3 PROFINET I/O Modules

Std Tgm 1

Table 11 Std Tgm 1 Consume

| Bytes | Description |
|-------|-------------------------|
| 0 | Control Word MSB |
| 1 | Control Word LSB |
| 2 | Frequency Reference MSB |
| 3 | Frequency Reference LSB |

Table 12 Std Tgm 1 Produce

| Bytes | Description |
|-------|----------------------|
| 0 | Status Word MSB |
| 1 | Status Word LSB |
| 2 | Output Frequency MSB |
| 3 | Output Frequency LSB |

Std Tgm 1 + 5 PZD

Table 13 Std Tgm 1 + 5 PZD Consume

| Bytes | Description |
|-------|---------------------------|
| 0 | Control Word MSB |
| 1 | Control Word LSB |
| 2 | Frequency Reference MSB |
| 3 | Frequency Reference LSB |
| 4 | Configurable Output 1 MSB |
| 5 | Configurable Output 1 LSB |
| 6 | Configurable Output 2 MSB |
| 7 | Configurable Output 2 LSB |
| 8 | Configurable Output 3 MSB |
| 9 | Configurable Output 3 LSB |
| 10 | Configurable Output 4 MSB |
| 11 | Configurable Output 4 LSB |
| 12 | Configurable Output 5 MSB |
| 13 | Configurable Output 5 LSB |

Table 14 Std Tgm 1 + 5 PZD Produce

| Bytes | Description |
|-------|--------------------------|
| 0 | Status Word MSB |
| 1 | Status Word LSB |
| 2 | Output Frequency MSB |
| 3 | Output Frequency LSB |
| 4 | Configurable Input 1 MSB |
| 5 | Configurable Input 1 LSB |
| 6 | Configurable Input 2 MSB |
| 7 | Configurable Input 2 LSB |
| 8 | Configurable Input 3 MSB |
| 9 | Configurable Input 3 LSB |
| 10 | Configurable Input 4 MSB |
| 11 | Configurable Input 4 LSB |
| 12 | Configurable Input 5 MSB |
| 13 | Configurable Input 5 LSB |

Forty Byte IO

Table 15 Forty Byte IO Consume

| Bytes | Description |
|-------|-----------------------------|
| 0 | Control Word MSB |
| 1 | Control Word LSB |
| 2 | Frequency Reference MSB |
| 3 | Frequency Reference LSB |
| 4 | Torque Reference MSB <I> |
| 5 | Torque Reference LSB <I> |
| 6 | Torque Compensation MSB <I> |
| 7 | Torque Compensation LSB <I> |
| 8 | Reserved |
| 9 | Reserved |
| 10 | Reserved |
| 11 | Reserved |
| 12 | Analog Output 1 MSB |
| 13 | Analog Output 1 LSB |
| 14 | Analog Output 2 MSB |
| 15 | Analog Output 2 LSB |
| 16 | Digital Outputs MSB |
| 17 | Digital Outputs LSB |
| 18 | Reserved |
| 19 | Reserved |
| 20 | Reserved |
| 21 | Reserved |
| 22 | Reserved |
| 23 | Reserved |
| 24 | Reserved |
| 25 | Reserved |
| 26 | Reserved |
| 27 | Reserved |
| 28 | Reserved |
| 29 | Reserved |
| 30 | Configurable Output 1 MSB |
| 31 | Configurable Output 1 LSB |
| 32 | Configurable Output 2 MSB |
| 33 | Configurable Output 2 LSB |
| 34 | Configurable Output 3 MSB |
| 35 | Configurable Output 3 LSB |
| 36 | Configurable Output 4 MSB |
| 37 | Configurable Output 4 LSB |
| 38 | Configurable Output 5 MSB |
| 39 | Configurable Output 5 LSB |

<I> Not available in V1000-series drives.

Table 16 Forty Byte IO Produce

| Bytes | Description |
|-------|---------------------------------|
| 0 | Status Word MSB |
| 1 | Status Word LSB |
| 2 | Output Frequency MSB |
| 3 | Output Frequency LSB |
| 4 | Torque Reference MSB <1> |
| 5 | Torque Reference LSB <1> |
| 6 | PG Count Value MSB |
| 7 | PG Count Value LSB |
| 8 | Motor Speed MSB |
| 9 | Motor Speed LSB |
| 10 | Frequency Reference Monitor MSB |
| 11 | Frequency Reference Monitor LSB |
| 12 | Output Current MSB |
| 13 | Output Current LSB |
| 14 | Analog Input 1 MSB |
| 15 | Analog Input 1 LSB |
| 16 | DC Bus Voltage MSB |
| 17 | DC Bus Voltage LSB |
| 18 | Fault Code MSB |
| 19 | Fault Code LSB |
| 20 | Alarm Code MSB |
| 21 | Alarm Code LSB |
| 22 | Output Power MSB |
| 23 | Output Power LSB |
| 24 | Analog Input 2 MSB |
| 25 | Analog Input 2 LSB |
| 26 | Digital Inputs MSB |
| 27 | Digital Inputs LSB |
| 28 | Analog Input 3 MSB |
| 29 | Analog Input 3 LSB |
| 30 | Configurable Input 1 MSB |
| 31 | Configurable Input 1 LSB |
| 32 | Configurable Input 2 MSB |
| 33 | Configurable Input 2 LSB |
| 34 | Configurable Input 3 MSB |
| 35 | Configurable Input 3 LSB |
| 36 | Configurable Input 4 MSB |
| 37 | Configurable Input 4 LSB |
| 38 | Configurable Input 5 MSB |
| 39 | Configurable Input 5 LSB |

<1> Not available in V1000-series drives.

■ Cyclic Messaging

SI-EP3 supports cycle times of 8 to 512 ms.



CW: Control Word

SW: Status Word

REF: Reference

ACT: Actual Value

PZD: Configurable inputs and outputs

■ Yaskawa Acyclic Parameter Access Mechanism

All drive parameters can be read and written under address 0x8000 by performing a read or write with the index value of the corresponding parameter address in the drive. Refer to the drive Technical Manual for a list of these parameter addresses.

■ PROFIdrive Acyclic Parameter Access Mechanism

A PROFIdrive acyclic parameter access mechanism can be used to access PROFIdrive parameters and drive parameters using an index of 0xB02E and the structure in [Figure 11](#) for write and read requests.

Requests and responses between the IO device and the IO controller or the IO supervisor are transferred with the Record Data Objects.

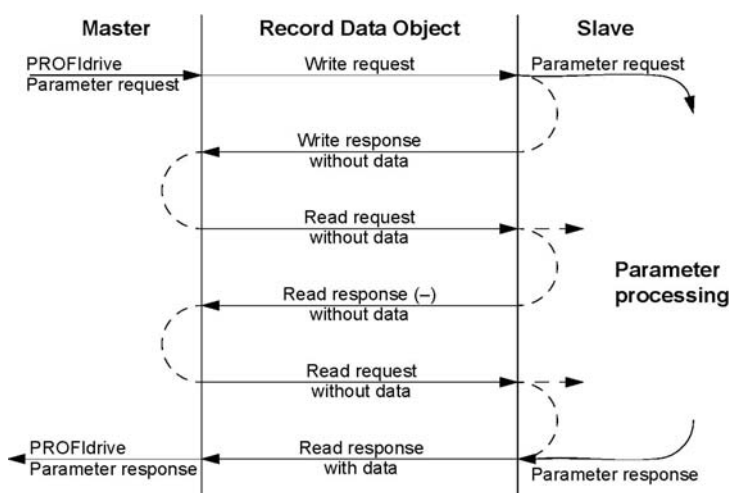

Figure 12 PROFIdrive Acyclic Parameter Access Mechanism Structure

8 Communication

A write request is first sent containing the parameter request.

If the write request is valid, the SI-EP3 acknowledges it with request accepted. The master then sends a read request. If the SI-EP3 is still busy performing the internal parameter request, it will return a negative response with the error code “0xB5” (State conflict). In this case, the master repeats the read request until the SI-EP3 has the PROFIdrive response data ready.

If the write request is invalid, a negative response is returned with an error code.

Base Mode Parameter Access - Local

The DO-ID field in the Record Data Object request header is not evaluated by the parameter manager. Parameters can be read through any slot in the configuration.

Table 17 Response Error Codes

| Byte | Value and Meaning |
|-------------|---|
| ErrorCode | 0xDF (Error Write) |
| | 0xDE (Error Read) |
| ErrorDecode | 0x80 (PNIORW) ErrorCode1 decoded according to Table 18 . ErrorCode2 is 0. |
| | 0x81 (PNIO) ErrorCode1 and ErrorCode2 decoded according to Table 18 . |
| ErrorCode1 | Error class and error code (Refer to Table 18). |
| ErrorCode2 | Not described |

Table 18 ErrorCode1 with PNIO RW Decoding

| Error class | Meaning | Error Code |
|-------------------------|---------------|-------------------------------|
| 0...9 | (Reserved) | - |
| 10 (0x0A) | Application | 0 = Read error |
| | | 1 = Write error |
| | | 2 = Module failure |
| | | 3...7 = Reserved |
| | | 8 = Version conflict |
| | | 9 = Feature not supported |
| | | 10...15 = User-specific |
| 11 (0x0B) | Access | 0 = Invalid index |
| | | 1 = Write length error |
| | | 2 = Invalid slot |
| | | 3 = Type conflict |
| | | 4 = Invalid area |
| | | 5 = State conflict |
| | | 6 = Access denied |
| | | 7 = Invalid range |
| | | 8 = Invalid parameter |
| | | 9 = Invalid type |
| 10...15 = User-specific | | |
| 12 (0x0C) | Resource | 0 = Read constraint conflict |
| | | 1 = Write constraint conflict |
| | | 2 = Resource busy |
| | | 3 = Resource unavailable |
| | | 4...7 = Reserved |
| | | 8...15 = User-specific |
| 13...15 | User-specific | - |

Read block is used in read requests and responses. Write block is used in write requests and responses. The request consists of unique identifiers for the connection, addressing information and length of the record data. The response also contains two additional fields for transferring information.

Table 19 Structure of the Read and Write Blocks

| Field(s) | Description | Range | Type |
|------------------------------------|--|-----------------------------------|--|
| Service | Request or Response service. | Request (0x00) Response (0x80) | UI8 |
| Operation | Read or Write operation. | Write (0x08) Read (0x09) | UI8 |
| Block length | Length of the block. | 0 ... 0xFFFF | UI16 |
| ARUUID | Identifier - time low - time mid - time high and version - clock - node | - | UI32 UI16 UI16 Octet[2] Octet[6] |
| API | Application Process Identifier | Device Access Point (0x0000) | UI32 |
| | | PROFIdrive (0x3A00) | |
| Slot | Slot of the Module Access Point (MAP/PAP) | 0x01 | UI16 |
| Sub-slot | Sub-slot of the Module Access Point (MAP/PAP) | 0x01 | UI16 |
| Padding | 2 bytes | | |
| Index | Index of the Record Data Object | 0x0001 - 0x7FFF 0xB02E | UI16 |
| Data length | Length of the data block | 0...0xFFFFFFFF | UI32 |
| Additional value 1 (response only) | Field for transferring additional data | - | UI16 |
| Additional value 2 (response only) | Field for transferring additional data | - | UI16 |
| Padding | 24 bytes for request, 20 bytes for response. | | |
| Data block | Used only with write request and read response. | | |

Data block contains PROFIdrive specific request or response header.

Table 20 PROFIdrive Request Header

| Field(s) | Description | Range | Byte/ Word |
|-------------------------|---|---|------------------|
| Request Reference | Unique identification set by the master. Changed for each new request. | 1 ... 255 | Byte |
| Request ID | Request type for the issued block. | Request Parameter (0x01) Change Parameter (0x02) | Byte |
| DO-ID | To be set to 0x01. | 0 ... 255 | Byte |
| No. of Parameters | Number of parameters that are present in the request. | 1 | Byte |
| Attribute | Type of object being accessed. | Value (0x10) | Byte |
| No. of Elements | Number of array elements accessed or length of string accessed. Set to 0 if non-array parameters are used. | 0, 1 ... 234 | Byte |
| Parameter Index (group) | Address of the PROFIdrive parameter that is being accessed. Also "1" is allowed by SI-EP3 to access drive parameters. Drive parameter group when accessing drive parameters. | 1 ... 65535 | Word |
| Subindex (parameter) | Addresses the first array element of the parameter. Drive parameter number when accessing drive parameters. | 0 ... 65535 | Word |
| Format <I> | Refer to Table 22 for details. | - | Byte |
| Number of Values <I> | Number of values following. | 1 | Byte |
| Values <I> | The values of the request. In case of odd number of bytes, a zero byte is appended to ensure the word structure of the telegram. | Varies based on value | See Format Field |

<I> Only when Request ID is 0x02 (Change Parameter). The Format, Number of Values, and Value Fields are repeated for other parameters.

Table 21 PROFIdrive Response Header

| Field(s) | Description | Range |
|----------------------|---|---|
| Response Reference | Mirrored from the request. | 1 ... 255 |
| Response ID | Response from the slave. In the event that requested services fail, a “not acknowledged” (NAK) response will be indicated. | Request Param OK (0x01) Request Param NAK (0x81) Change Param OK (0x02) Change Param NAK (0x82) |
| DO-ID | To be set to 1. | 0 ... 255 |
| No. of Parameters | Number of parameters that are present in the response. | 1... 37 |
| Format <I> | Refer to Table 22 for details. | - |
| Number of Values <I> | Number of values following. | 0 ... 234 |
| Values <I> | The values of the request. When there is an odd number of bytes, a zero byte is appended to ensure the word structure of the telegram. | Varies based on value |

<I> Only when Request ID is 0x01 (Request Parameter OK). The Format, Number of Values, and Value Fields are repeated for other parameters.

Table 22 Data Types for Format Field

| Code | Type |
|---------------|---------------------|
| 0x00 | (Reserved) |
| 0x01...0x36 | Standard data types |
| 0x37...0x3F | (Reserved) |
| 0x40 | Zero |
| 0x41 | Byte |
| 0x42 | Word |
| 0x43 | Double word |
| 0x44 | Error |
| 0x45 ... 0xFF | (Reserved) |

Table 23 PROFIdrive Parameter Request Error Codes

| Error # | Meaning | Used at |
|--------------|--|--|
| 0x00 | Impermissible parameter number | Access to unavailable parameter |
| 0x01 | Parameter value cannot be changed | Change access to a parameter value that cannot be changed |
| 0x02 | Low or high limit exceeded | Change access with value outside the limits |
| 0x03 | Invalid subindex | Access to unavailable subindex |
| 0x04 | No array | Access with subindex to non-indexed parameter |
| 0x05 | Incorrect data type | Change access with value that does not match the data type of the parameter |
| 0x06 | Setting not permitted (can only be reset) | Change access with value unequal to 0 when this is not permitted |
| 0x07 | Description element cannot be changed | Change access to a description element that cannot be changed |
| 0x09 | No description data available | Access to unavailable description (parameter value is available) |
| 0x0B | No operation priority | Change access rights without rights to change parameters |
| 0x0F | No text array available | Access to text array that is not available (parameter value is available) |
| 0x11 | Request cannot be executed because of operating mode | Access is temporarily not possible for reasons that are not specified in detail |
| 0x14 | Value impermissible | Change access with a value that is within limits but is not permissible for other long-term reasons (parameter with defined single values) |
| 0x15 | Response too long | The length of the current response exceeds the maximum transmittable length |
| 0x16 | Parameter address impermissible | Illegal value or value that is not supported for the attribute, number of elements, parameter number or sub-index, or a combination |
| 0x17 | Illegal format | Write request: Illegal format or format of parameter data that is not supported |
| 0x18 | Number of values inconsistent | Write request: Number of values of parameter data does not match number of elements at the parameter address |
| 0x19 | DO nonexistent | Request to DO, which does not exist |
| 0x65... 0xFF | Manufacturer-specific | - |

| Error # | Meaning | Used at |
|---------|-----------------------|---|
| 0x65 | Vendor-specific error | Vendor-specific error |
| 0x66 | Request not supported | Request not supported |
| 0x67 | Communication error | Request cannot be completed because of communication error |
| 0x6F | Time-out error | Request aborted due to time-out |
| 0x78 | PZD map failure | Parameter cannot be mapped to PZD (size mismatch or non-existent) |
| 0x79 | PZD memory failure | Parameter cannot be mapped to PZD (out of memory) |
| 0x7A | Multiple PZD map | Parameter cannot be mapped to PZD (multiple PZD write) |
| 0x8C | Set torque mode error | Cannot change mode to TORQUE (frequency is used) |
| 0x90 | Illegal Request ID | The request ID of the response is illegal |

Parameter Data Transfer Examples

The following example shows how parameter data is transferred using the acyclic parameter access mechanism's READ and WRITE.

Example 1: Reading a drive parameter

To read a Yaskawa Drive parameter, use the PNU of 1 and the actual address of the parameter in the SubIndex.

Write Request (Read Parameter Value)

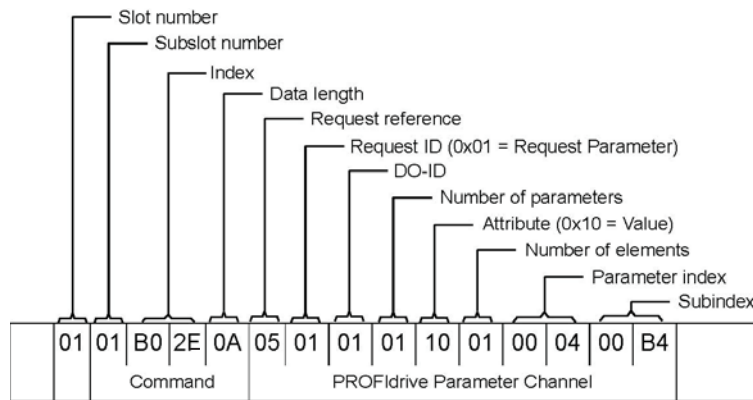

Positive Read Response to Read Request

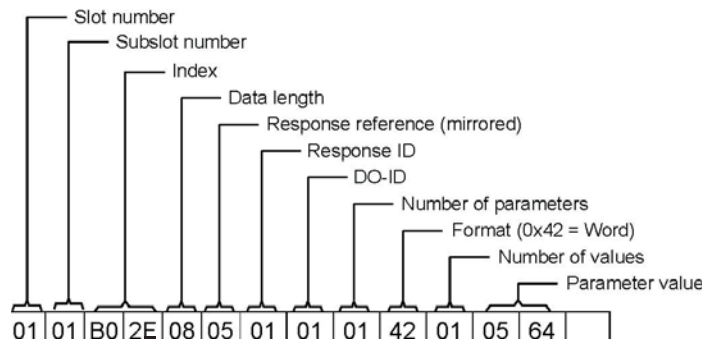

PROFIdrive Parameter Channel

8 Communication

Negative Response to PROFIdrive Read Request

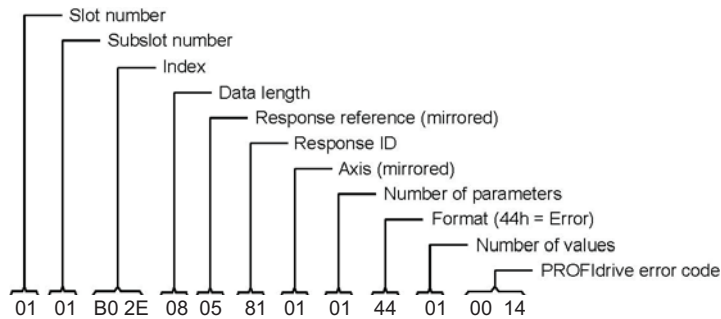

PROFIdrive Profile-Specific Parameters

PROFIdrive parameters contain data of the drive in standard form. The table below describes the supported PROFIdrive parameters.

| Parameter | R/W | Data type | Description |
|-----------|-----|----------------------|---|
| 922 | R | Unsigned16 | Telegram selection |
| 944 | R | Unsigned16 | Fault message counter |
| 947 | R | Array [5] Unsigned16 | Fault number. (coded according to DRIVECOM profile) Subindex Contents, see parameter 945. |
| 964 | R | Array [6] Unsigned16 | Device identification Subindex Contents 0 Manufacturer 1 Device type 2 Version 3 Firmware date (year) 4 Firmware date (day/month) 5 Number of Drive Objects (DO) |
| 965 | R | Octet String2 | Profile number of this device. 0328h = Profile 3, Version 40 |
| 967 | R | Unsigned16 | Control word (CW) |
| 968 | R | Unsigned16 | Status word (SW) |
| 972 | R/W | Unsigned16 | Software reset Value Description 0 No action 1 Power-cycle PROFINET IO module The parameter must do a zero-to-one transition and the motor must be stopped. |
| 977 | R/W | Unsigned16 | Stores parameters to non-volatile memory Value Description 0 No action 1 Stores parameters The parameter must do a zero-to-one transition and the motor must be stopped. |
| 61000 | R | VisibleString24 | Name of station |
| 61001 | R | Unsigned32 | IP of station |
| 61002 | R | Array [6] Unsigned8 | MAC of station |
| 61003 | R | Unsigned32 | Default gateway of station |
| 61004 | R | Unsigned32 | Subnet mask of station |

Fault Buffer Mechanism

PROFIdrive profile has a mechanism that can store five fault situations to PROFIdrive parameters. Fault and diagnostic data, like fault number and fault code can be accessed simultaneously with only one subindex. The mechanism consists of two PROFIdrive parameters:

- PNU944: Fault message counter
- PNU947: Fault numbers according to value in U2-01

◆ Option High Priority Alarm Codes

These codes are transmitted as Manufacturer Specific Diagnostic high priority alarms that can be seen in the PLC configuration software. These high priority codes are the same codes that appear in the drive manual, except with an offset of 0x1000.

Table 24 PROFINET Option High Priority Alarm Codes

| Drive Alarm Code (hex) <1> | Description | Corrective Action |
|----------------------------|-----------------------------|--|
| 1000 | None | - |
| 1001 | DC Bus Fuse Open (PUF) | Output Transistor Failure. Replace the drive |
| 1002 | DC Bus Undervolt (Uv1) | Input power fluctuation too large |
| 1003 | CTL PS Undervolt (Uv2) | Cycle drive power and replace drive if fault continues |
| 1004 | MC Answerback (Uv3) | Cycle drive power and replace drive if fault continues |
| 1005 | Short Circuit (SC) | <ul style="list-style-type: none"> • Check drive wiring • Cycle drive power and replace drive if fault continues. |
| 1006 | Ground Fault (GF) | Check for motor and/or cable damage |
| 1007 | Over Current (oC) | Check motor, motor load and accel/decel rates |
| 1008 | DC Bus Overvolt (oV) | <ul style="list-style-type: none"> • Check incoming voltage • Check deceleration time |
| 1009 | Heatsink Overtemp (oH) | <ul style="list-style-type: none"> • Check ambient temperature • Check drive cooling fan |
| 100A | Heatsink Max Temp (oH1) | Check drive cooling fan |
| 100B | Motor Overload (oL1) | <ul style="list-style-type: none"> • Check the load, accel/decel and cycle times • Check motor rated current (E2-01) |
| 100C | Inv Overload (oL2) | <ul style="list-style-type: none"> • Check the load, accel/decel and cycle times • Check drive rating |
| 100D | Overtorque Det 1 (oL3) | <ul style="list-style-type: none"> • Check L6-02 and L6-03 settings • Check system mechanics |
| 100E | Overtorque Det 2 (oL4) | <ul style="list-style-type: none"> • Check L6-05 and L6-06 settings • Check system mechanics |
| 100F | DynBrk Transistor (rr) | Cycle drive power and replace drive if fault continues |
| 1010 | DynBrk Resistor (rH) | Check load, operating speed and deceleration time |
| 1011 | External Fault 3 (EF3) | <ul style="list-style-type: none"> • Multifunction digital input set to external fault • Circuit at terminal is closed |
| 1012 | External Fault 4 (EF4) | |
| 1013 | External Fault 5 (EF5) | |
| 1014 | External Fault 6 (EF6) | |
| 1015 | External Fault 7 (EF7) | |
| 1016 | External Fault 8 (EF8) <2> | |
| 1017 | Heatsink Fan (FAn) | Check drive cooling fan |
| 1018 | Overspeed Det (oS) | <ul style="list-style-type: none"> • Check reference and reference gain • Check F1-08 and F1-09 settings |
| 1019 | Speed Deviation (dEV) | <ul style="list-style-type: none"> • Check load, accel/decel times and system mechanics • Check F1-10 and F1-11 settings |
| 101A | PG Open (PGo) <2> | Check PG card connections |
| 101B | Input Phase Loss (PF) | Excessive input voltage fluctuation |
| 101C | Output Phase Loss (LF) | <ul style="list-style-type: none"> • Check for broken wire/loose terminals • Check motor rating |
| 101D | None | - |
| 101E | Operator Disconnected (oPr) | Reconnect the digital operator |
| 101F | EEPROM R/W Error (Err) | Cycle drive power and replace drive if fault continues |
| 1020 | None | - |

8 Communication

| Drive Alarm Code (hex) <1> | Description | Corrective Action |
|----------------------------|------------------------|--|
| 1021 | Comm Error (bUS) | <ul style="list-style-type: none">• Check network cable connections.• Check 24 Vdc power supply voltage |
| 1022 | | Check option installation and connections. |
| 1023 | | Cycle drive power and replace option or drive if fault continues. |
| 1024 | | |
| 1025 | Out of Control (CF) | <ul style="list-style-type: none">• Check motor parameters• Auto-tune |
| 1027 | External Fault 0 (EF0) | <ul style="list-style-type: none">• Check PLC program• Check MI switch setting• Check option LEDs for fault indication |

<1> Drive error code is stored in MEMOBUS/Modbus address 0080 hex.

<2> Not available in V1000-series drives.

◆ Option Low Priority Alarm Codes

These codes are transmitted as Manufacturer Specific Diagnostic low priority alarms that can be seen in the PLC configuration software. These low priority codes are the same codes that appear in the drive manual, except with an offset of 0x1000.

Table 25 PROFINET Option Low Priority Alarm Codes

| Drive Alarm Code (hex) <1> | Description | Drive Alarm Code (hex) <1> | Description |
|----------------------------|---|----------------------------|--|
| 0401 | Undervoltage (Uv) | 0420 | MEMOBUS/Modbus Test Mode Fault (SE) |
| 0402 | Overvoltage (ov) | 0422 | Motor Overheat (oH3) |
| 0403 | Heatsink Overheat (oH) | 0427 | PID Feedback Loss (FbL) |
| 0404 | Drive Overheat (oH2) | 0428 | PID Feedback Loss (FbH) |
| 0405 | Overtorque 1 (oL3) | 042A | Drive Disabled (dnE) |
| 0406 | Overtorque 2 (oL4) | 042B | PG Disconnected (PGo) <2> |
| 0407 | Rum Command Input Error (EF) | 0431 | Option Watchdog Error (E5) |
| 0408 | Drive Baseblock (bb) | 0432 | Option Station Address Setting Error (AEr) |
| 0409 | External Fault 3, input terminal S3 (EF3) | 0433 | Option Comm. Cycle Setting Error (CyC) |
| 040A | External Fault 3, input terminal S4 (EF4) | 0434 | High Current Alarm (HCA) |
| 040B | External Fault 3, input terminal S5 (EF5) | 0435 | Cooling Fan Maintenance Time (LT-1) |
| 040C | External Fault 3, input terminal S6 (EF6) | 0436 | Capacitor Maintenance Time (LT-2) |
| 040D | External Fault 3, input terminal S7 (EF7) | 0438 | Option EEPROM Error (EEP) |
| 040E | External Fault 3, input terminal S8 (EF8) <2> | 0439 | External Fault (input terminal S1) (EF1) |
| 040F | Cooling Fan Error (FAn) | 043A | External Fault (input terminal S2) (EF2) |
| 0410 | Overspeed (oS) | 043B | Safe Disable Input (HbbF) |
| 0411 | Excessive Speed Deviation (dEv) | 043C | Safe Disable Input (Hbb) |
| 0412 | PG Disconnected (PGo) <2> | 043D | Mechanical Weakening Detection 1 (oL5) |
| 0414 | MEMOBUS/Modbus Comm. Error (CE) | 043E | Mechanical Weakening Detection 2 (UL5) |
| 0415 | Option Communication Error (bUS) | 043F | PLC Alarm (PA1) |
| 0416 | Serial Comm. Transmission Error (CALL) | 0440 | PLC Alarm (PA2) |
| 0417 | Motor Overload (oL1) | 0441 | Output Voltage Detection Fault (voF) |
| 0418 | Drive Overload (oL2) | 0442 | IGBT Maintenance Time (90%) (TrPC) |
| 041A | Option Card External Fault (EF0) | 0443 | Soft Charge Bypass Relay Maintenance Time (LT-3) |
| 041B | Motor Switch Command Input during Run (rUn) | 0444 | IGBT Maintenance Time (50%) (LT-4) |
| 041D | Serial Comm. Transmission Error (CALL) | 0445 | Braking Transistor Overload (boL) |
| 041E | Undertorque Detection 1 (UL3) | 0448 | Motor Overheat (NTC Input) (oH5) |
| 041F | Undertorque Detection 2 (UL4) | 0449 | DriveWorksEZ Alarm (dWAL) |

<1> Drive error code is stored in MEMOBUS/Modbus address 0080 hex.

<2> Not available in V1000-series drives.

◆ Identification and Maintenance Functions (I&M)

The purpose of the I&M functions is to provide support for the customer during commissioning, parametrization and repair of the module. SI-EP3 supports I&M function 0, which can be accessed using the Record data object's read request.

| Function | Record Data Index |
|----------|-------------------|
| I&M0 | 0xAFF0 |

Structure of the I&M functions is described in the following tables.

Table 26 I&M0 Device Identification (Read-Only)

| Content | Size | Description |
|-------------------------|----------|---|
| Header | 10 bytes | - |
| Vendor ID | 2 bytes | PROFINET Vendor ID of Yaskawa, which is 0x019F |
| Order ID | 20 bytes | Order number of the SI-EP3 adapter kit (SI-EP3) |
| Serial number | 16 bytes | Serial number of the adapter |
| Hardware revision | 2 bytes | Hardware revision of the SI-EP3 adapter |
| Software revision | 4 bytes | Revision of the software |
| Revision counter | 2 bytes | Number of revision |
| Profile ID | 2 bytes | PROFIdrive (0x3A00) |
| Profile specific type | 2 bytes | No profile specific type (0x0000) |
| I&M version | 2 bytes | Version is 1.1 (0x0101) |
| Supported I&M functions | 2 bytes | I&M0 is supported (0x0001) |

◆ Diagnostic and Alarms

SI-EP3 has mechanisms for sending alarms and saving diagnostics data to fault buffer. Alarm will be triggered if the host or drive has faults in communication or operation. There are three types of faults:

| Fault | API/Slot/Sub-slot | Channel Error Type |
|-------------|-------------------|---------------------------|
| Drive Fault | 0x3A00 / 1 / 1 | A fault declared in drive |

◆ Alarm Mechanism

When a fault or alarm situation occurs in the drive, the SI-EP3 adapter will send an alarm notification, which the master station must acknowledge. Refer to [Table 27](#) for details.

Table 27 Alarm Notification

| Attribute | Description |
|-------------------------|--|
| BlockHeader | - |
| AlarmType | PROFINET specific alarm type |
| API | 0x3A00 (PROFIdrive profile) |
| SlotNumber | Slot number of the Drive Object (DO) |
| SubslotNumber | Sub-slot number of the sub-slot to which the diagnosis object is related |
| ModuleIdentNumber | Module Ident number of the DO |
| SubmoduleIdentNumber | 0xFFFF |
| AlarmSpecifier | Diagnosis type |
| UserStructureIdentifier | 0x8000 (Channel Diagnosis Data) |
| ChannelNumber | 0 |
| ChannelProperties | 0x0800 Diagnosis Appears 0x1000 Diagnosis Disappears |
| ChannelErrorType | Error code of drive fault or drive alarm |

9 Web Interface

The web server interface to the drive option through port 80 allows management of diagnostic information through a standard web browser. The web page is a Java applet that creates a tabbed web page. The available tabs include:

- Main Tab
- Drive Status Tab
- Network Tab
- Doc links Tab
- Email Alerts Tab
- Parameter Access Tab^{<1>}
- Configuration Tab^{<1>}
- Custom Tab

Note: PCs must have Java SE 6 Update 14 or later installed to view the web pages. PCs without Java will display web pages with limited features.

Access the web server interface by typing the IP address of the SI-EP3 option in a web browser address.

Example: "http://192.168.1.20"

The SI-EP3 IP Address is available using drive digital operator to access Option Monitors U6-80 to U6-83.

[Refer to Option Monitors on page 20.](#)

◆ Main Tab

The Main tab shows basic option information such as IP address, MAC address, and firmware version.



Figure 13 Main Tab View

^{<1>}The Parameter Access Tab and Configuration Tab are only accessible after entering a valid password.

◆ Drive Status Tab

The Drive Status tab shows basic I/O information and drive state information.

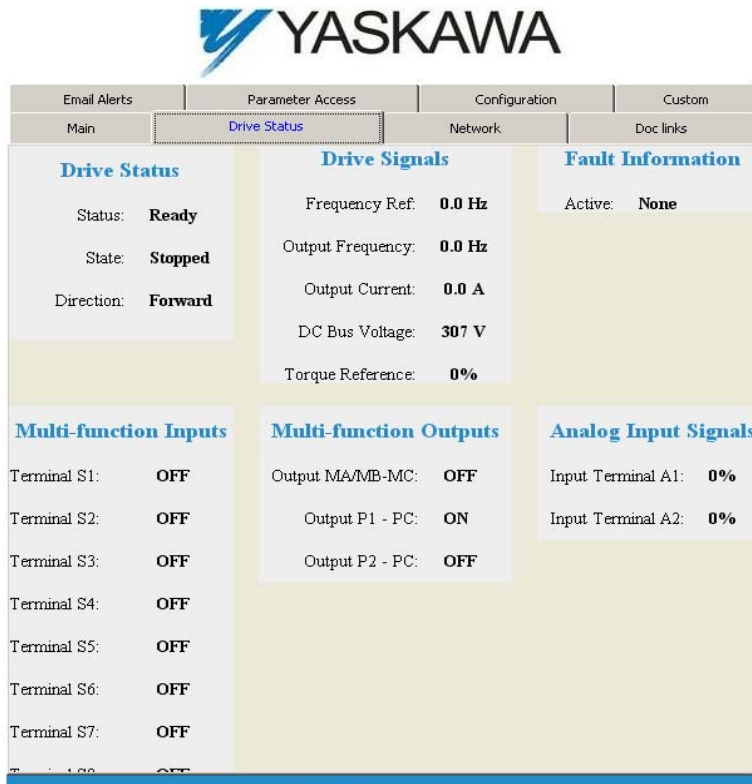

Figure 14 Drive Status Tab View

◆ Network Tab

The Network tab shows the status of the option network traffic and the status of open I/O connections.



Figure 15 Network Tab View

Table 28 Network Monitor Descriptions

| Network Monitor | Explanation |
|-------------------------------|---|
| Msg Tx OK | Cumulative number of messages transmit successfully from SI-EP3. |
| Msg Rx OK | Cumulative number of messages received successfully to SI-EP3. |
| Current Connections | Current number of open connections. |
| Control Connection Delta Time | The time between the last two writes to the Control register, MEMOBUS/Modbus address 0001H. |
| Msg Tx Dropped | Cumulative number of messages dropped due to output network buffer being full and unable to hold the new message. |
| Msg Rx Dropped | Cumulative number of messages dropped due to input network buffer being full and unable to hold the new message. |
| Collisions | Cumulative number of collisions (half duplex only) reported by the MAC/PHY (Media Access Control/ Physical Connection). |
| Msg Tx Errors | Cumulative number of transmit underruns and transmit stops reported by the MAC/PHY. |
| Msg Rx Errors | Cumulative number of receive overruns, receive stops, and receive error frames reported by the MAC/PHY. |
| Tx Retry | Cumulative number of transmits in which the 1st attempt was delayed due to busy medium reported by the MAC/PHY. |

Note: Cumulative counters are reset when the power supply is cycled.

◆ Doc Links Tab

The Doc links tab contains links to the option documentation on the Yaskawa website.

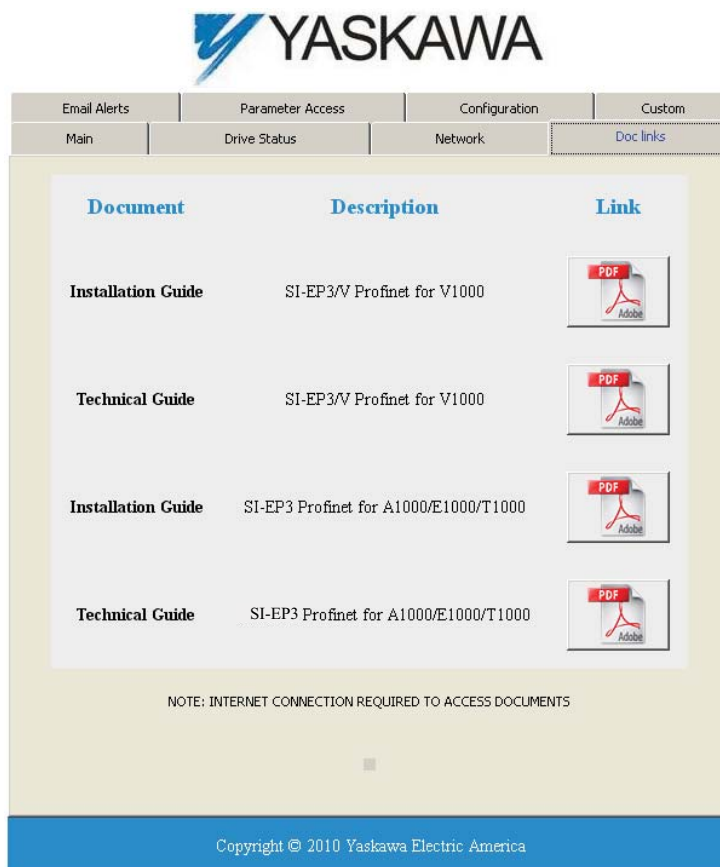

Figure 16 Doc Links Tab View

◆ Email Alerts Tab

The Email Alerts tab allows the user to configure four Email Fault/Alarm conditions. When the condition is true, one email will be sent to the provided email address. Another email will not be sent until the condition becomes false and then true again. A 30-second timer prevents emails from being sent when conditions reoccur immediately after being removed. The timer helps limit the amount of emails sent regarding the same intermittent condition and helps to reduce network traffic by reducing emails about reoccurring errors.

The screenshot displays the 'Email Alerts' configuration page with four sections, each for a 'Conditional Email'. Each section includes an 'Email Active' checkbox, a 'Condition' field with a dropdown menu, a comparator, a value, a logical operator (OR/AND), a unit (Hz), an 'Address' field, a 'Subject' field, and a 'Message' text area. At the bottom, there are 'Save to device' and 'Cancel and reload' buttons.

| Conditional Email | Condition | Comparator | Value | Operator | Unit | Address | Subject | Message |
|---------------------|---------------------|------------|-------|----------|------|---------------------------|----------------|---|
| Conditional Email 1 | Frequency Reference | >= | 3000 | OR | Hz | 4140000000@email.uscc.net | This works | Is this saved |
| Conditional Email 2 | Frequency Reference | >= | 3000 | OR | Hz | 4140000000@email.uscc.net | Got this fault | Hello you, this is a fault, another coming in 30 seconds hopefully. |
| Conditional Email 3 | Frequency Reference | < | 0 | AND | Hz | ToAddress3@ToDomain3 | Subject3 | Text3 |
| Conditional Email 4 | Frequency Reference | < | 0 | AND | Hz | ToAddress4@ToDomain4 | Subject4 | This is the text for Fault 1. |

Figure 17 Email Alerts Tab View

■ Procedure: Conditional Email Set-up

1. Define the condition that will trigger the email by selecting a monitor parameter, a comparator, and a value. Set up comparator values for the range of values to check in the chosen condition. If choosing only one condition and no OR or AND are needed, set the "OR/AND" drop-down selection to "NotUsed".
2. Enter the email address where the alert will be sent.
3. Enter the message that will appear in the email contents.
4. Enter the email subject.
5. Click the "Email Active" check box to enable the alert.

Clicking "Save to device" will save the entered information into the option memory.

Clicking "Cancel and reload" will cancel any pending edits and display the most recently saved settings from the option board.

◆ Parameter Access Tab

The Parameter Access tab allows the user to read and write parameters from the drive. Write access is restricted until a valid password is entered.

The screenshot shows the YASKAWA web interface with the 'Parameter Access' tab selected. The main content area is titled 'Modbus Parameters'. It contains three rows of controls:

- Modbus Address (hex):** A text input field containing '0x0001' and a 'Read' button.
- Decimal Value:** An empty text input field and a 'Set' button.
- Hex Value:** An empty text input field and a 'Set' button.

At the bottom of the form, the status is displayed as 'Waiting'.

Figure 18 Parameter Access Tab View

The MEMOBUS/Modbus address for the drive parameter being accessed must be entered in hexadecimal. The number must begin with “0x” to signify hexadecimal.

Clicking “Read” will load and display the current value of the given MEMOBUS/Modbus Address. Clicking “Set” will save the given value to the given MEMOBUS/Modbus address.

After a “Read” or “Set” command is given, Status will display “Waiting” while the action is being carried out, then “Complete” is displayed when finished.

◆ Configuration Tab

The Configuration tab sets web page behavior parameters. Access is restricted unless a valid password is entered.

The screenshot shows the YASKAWA web interface with the 'Configuration' tab selected. The page is divided into four main sections:

- Security Login:** Includes a 'Password:' input field, a 'Log out' button, and a status of 'Logged in'.
- Change Password:** Includes 'New Password:' and 'Confirm Password:' input fields, a 'Change password' button, and a status of 'Idle'.
- Option Card:** Includes an 'Applied Refresh Rate (ms):' input field (set to 1000), radio buttons for 'Parameter Security' (Disabled is selected), a 'Save Option Card Parameters' button, and a status of 'Idle'.
- Email Settings:** Includes 'Email Server IP:', 'Email Port:', and 'From' Email Address:' input fields, and a 'Submit Email Parameters' button.

At the bottom of the page, there is a large button labeled 'Save Configuration Parameters To Flash'.

Figure 19 Configuration Tab View

■ Security Login

Enter a valid password and click “Log in”. The button text will change to “Log out” and the status will change to “Logged in”.

Note: The default security password is “yaskawa”.

This password can be changed in the “Change Password” section of the tab. Entering a valid password allows access to the settings in the Configuration tab, Email Alerts tab, and the Parameter Access tab.

■ Change Password

To change the password, enter the new password in the “New Password:” and “Confirm Password:” text boxes then click “Change password”. The Status display will change to “Idle” then “Changing Password” then “Password Changed”. If the passwords in the two text boxes do not match, the Status will display “Passwords don’t match”.

■ Option Card

The values displayed in the various tabs are refreshed at the rate defined in the “Applet Refresh Rate (ms)” text box. Enter values in the range of 1000 ms to 65.535 seconds.

Parameter Security can be enabled or disabled by clicking one of the radio buttons. When “Disabled” is selected, no password is necessary and all functions in the web pages will be available. When “Enabled” is selected, a valid password must be entered to edit email settings and to write parameters.

■ Email Settings

The “Email Server IP” text box must contain the IP address of the email server. The subnet address is configured in drive parameters F7-05 through F7-08. The configured email alerts will use the server at this address when sending emails.

Enter the email server port in the “Email Port” text box.

The value in the “From’ Email Address” text box identifies the origin of the email alerts to the recipient.

Click “Submit Email Parameters” to save the email settings to the option.

Click “Save Configuration Parameters to Flash” to save the entered values from this tab into non-volatile memory. These values will then be remembered after cycling power.

■ General Settings

Click “Save Options Card Parameters” to save the Applet Refresh Rate and the Parameter Security settings to the option.

◆ Custom Tab

The Custom tab displays a selection of quick setting parameters.

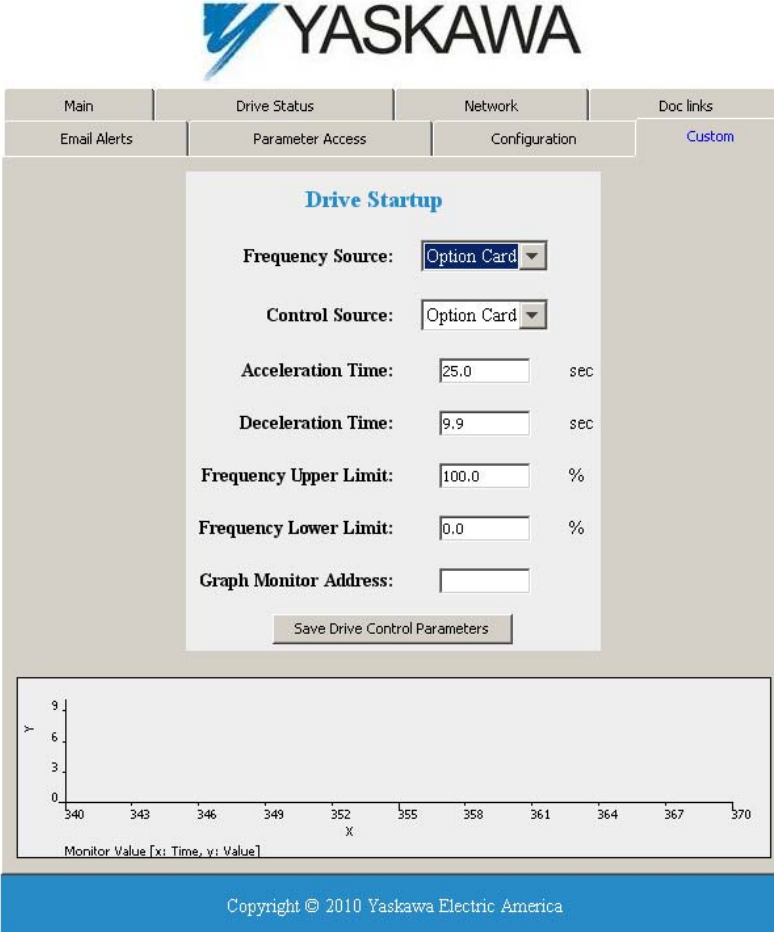

The screenshot displays the YASKAWA web interface for the Custom tab. At the top, the YASKAWA logo is visible. Below it, a navigation bar includes tabs for Main, Drive Status, Network, and Doc links. Underneath, there are sub-tabs for Email Alerts, Parameter Access, Configuration, and Custom (which is currently selected). The main content area is titled "Drive Startup" and contains several configuration fields:

- Frequency Source:** A dropdown menu set to "Option Card".
- Control Source:** A dropdown menu set to "Option Card".
- Acceleration Time:** A text input field containing "25.0" followed by "sec".
- Deceleration Time:** A text input field containing "9.9" followed by "sec".
- Frequency Upper Limit:** A text input field containing "100.0" followed by "%".
- Frequency Lower Limit:** A text input field containing "0.0" followed by "%".
- Graph Monitor Address:** An empty text input field.

Below these fields is a "Save Drive Control Parameters" button. At the bottom of the configuration area is a graph with a vertical Y-axis (0 to 9) and a horizontal X-axis (340 to 370). The X-axis is labeled "Monitor Value [x: Time, y: Value]". The graph area is currently empty. At the very bottom of the interface, a blue footer bar contains the text "Copyright © 2010 Yaskawa Electric America".

Figure 20 Custom Tab View

10 Troubleshooting

◆ Drive-Side Error Codes

Drive-side error codes appear on the drive digital operator. Causes of the errors and corrective actions are listed in [Table 29](#). For additional error codes that may appear on the drive digital operator, refer to the drive Technical Manual.

■ Faults

Both bUS (SI-EP3 option communication error) and EF0 (External fault input from the SI-EP3 option) can appear as an alarm or as a fault. When a fault occurs, the digital operator ALM LED remains lit. When an alarm occurs, the ALM LED flashes.

If communication stops while the drive is running, use the following questions as a guide to help remedy the fault:

- Is the option properly installed?
- Is the communication line properly connected to the option? Is it loose?
- Is the controller program working? Has the controller/PLC CPU stopped?
- Did a momentary power loss interrupt communications?

Table 29 Fault Display and Possible Solutions

| LED Operator Display | | Fault Name |
|---|-----|--|
| <i>bUS</i> | bUS | Option Communication Error. |
| | | <ul style="list-style-type: none"> • After establishing initial communication, the connection was lost • Only detected when the run command or frequency reference is assigned to the option (b1-01 = 3 or b1-02 = 3) |
| Cause | | Possible Solution |
| Master controller (PLC) has stopped communicating | | <ul style="list-style-type: none"> • Check that power is supplied to the PLC • Check that PLC is not in program mode |
| Communication cable is not connected properly | | <ul style="list-style-type: none"> • Check for faulty wiring • Correct any wiring problems |
| A data error occurred due to noise | | <ul style="list-style-type: none"> • Check the various options available to minimize the effects of noise • Counteract noise in the control circuit, main circuit, and ground wiring • If a magnetic contactor is identified as a source of noise, install a surge absorber to the contactor coil • Make sure the cable used meets the PROFINET requirements • Make sure the option ground wire is connected between option FE terminal and the drive ground terminal connected to earth ground |
| Option is damaged | | If there are no problems with the wiring and the error continues to occur, replace the option. |

| LED Operator Display | | Fault Name |
|---|-----|--|
| <i>EF0</i> | EF0 | External fault input from option. |
| | | The alarm function for an external device has been triggered. |
| Cause | | Corrective Action |
| An external fault is being sent from the upper controller (PLC) | | <ul style="list-style-type: none"> • Remove the cause of the external fault • Reset the external fault input from the PLC device |
| Problem with the PLC program | | Check the program used by the PLC and make the appropriate corrections. |

| LED Operator Display | | Fault Name |
|--|-------|--|
| oFA00 | oFA00 | Option fault. |
| | | Option is not properly connected. |
| Cause | | Possible Solution |
| Non-compatible option connected to the drive | | Connect an option that is compatible with the drive. |

| LED Operator Display | | Fault Name |
|--|-------|---|
| oFA01 | oFA01 | Option fault. |
| | | Option is not properly connected. |
| Cause | | Possible Solution |
| Problem with the connectors between the drive and option | | Turn the power off and check the connectors between the drive and option. |

| LED Operator Display | | Fault Name |
|-----------------------|-------|--------------------------------|
| oFA03 | oFA03 | Option fault. |
| | | Option self-diagnostics error. |
| Cause | | Possible Solution |
| Option hardware fault | | Replace the option. |

| LED Operator Display | | Fault Name |
|-----------------------|-------|--------------------------|
| oFA04 | oFA04 | Option fault. |
| | | Option flash write mode. |
| Cause | | Possible Solution |
| Option hardware fault | | Replace the option. |

| LED Operator Display | | Fault Name |
|-----------------------|----------------|-------------------------|
| oFA30 to oFA43 | oFA30 to oFA43 | Option Fault (Port A). |
| | | Communication ID error. |
| Cause | | Possible Solution |
| Option hardware fault | | Replace the option. |

| LED Operator Display | | Fault Name |
|---|-------|--------------------------------------|
| oFb00 | oFb00 | Option fault (CN5-B). |
| | | Non-compatible option is connected. |
| Cause | | Possible Solution |
| Non-compatible option connected to the drive. | | Connect the correct option to CN5-A. |

| LED Operator Display | | Fault Name |
|---|-------|--|
| oFb02 | oFb02 | Option fault (CN5-B). |
| | | Two of the same options are connected at the same time. |
| Cause | | Possible Solution |
| Options AI-A3 or DI-A3 were connected to the CN5-B port while an option was already connected to CN5-A. | | <ul style="list-style-type: none"> • Only one type of AI-A3 or DI-A3 option can be connected to the drive. • The SI-EP3 option can only be connected to CN5-A. |

10 Troubleshooting

| LED Operator Display | | Fault Name |
|---|-------|--|
| oFc00 | oFc00 | Option fault (CN5-C). Non-compatible option is connected. |
| Cause | | Possible Solution |
| Non-compatible option connected to the drive. | | Connect the correct option to CN5-A. |

| LED Operator Display | | Fault Name |
|---|-------|--|
| oFc02 | oFc02 | Option fault. Option flash write mode. |
| Cause | | Possible Solution |
| Options AI-A3 or DI-A3 are connected to the CN5-B port with an option connected to CN5-A. | | <ul style="list-style-type: none"> Only one type of AI-A3 or DI-A3 option can be connected to the drive The SI-EP3 option can only be connected to CN5-A |

■ Minor Faults and Alarms

| LED Operator Display | | Minor Fault Name | |
|--|------|---|--------------------------|
| CALL | CALL | Serial communication transmission error. Communication is not established. | |
| Cause | | Possible Solution | Minor Fault (H2-□□ = 10) |
| Communication wiring is faulty, there is a short circuit, or improper connection | | Check for wiring errors: <ul style="list-style-type: none"> Correct the wiring Remove ground shorts and reconnect loose wires | YES |
| Programming error on the master side | | Check communications at start-up and correct programming errors. | |
| Communication circuitry is damaged. | | <ul style="list-style-type: none"> Perform a self-diagnostics check Replace the drive if the fault continues to occur | |

■ Option Fault Monitors U6-98 and U6-99

The option can declare error/warning conditions via drive monitor parameters on the drive digital operator as shown in [Table 30](#).

Table 30 Option Fault Monitor Descriptions

| Fault Condition | Fault Declared | Status Value (U6-98/U6-99) | Description |
|------------------------------|----------------|----------------------------|---|
| No Fault | n/a | 0 | No faults. |
| Force Fault | EF0 | 3 | Network sent a message to force this node to the fault state. |
| Network Link Down | BUS ERROR | 1300 | No network link to option board. |
| Network Failure | BUS ERROR | 1301 | Connection with PLC Timeout. |
| Default MAC Address | None | 1303 | Factory default MAC Address programmed into the option. Return for reprogramming. |
| No IP Address | None | 1304 | No IP Address has been programmed into the option. |
| No Station Name | None | 1305 | No Station Name has been programmed into the option. |
| Config Error | None | 1306 | Configuration error on power-up. |
| Init. Failure | None | 1307 | Initialize error on power-up. |
| Permanent Communication Loss | BUS ERROR | 1308 | Fatal error in MAC/PHY hardware, requires power cycle to recover. |

Two drive monitor parameters, U6-98 and U6-99 assist in network troubleshooting:

- U6-98 displays the first declared fault since the last power cycle. U6-98 is only cleared upon drive power-up.
- U6-99 displays the present option SI-EP3 status. U6-99 is cleared upon a network-issued fault reset and upon power-up.

If another fault occurs while the original fault is still active, parameter U6-98 retains the original fault value and U6-99 stores the new fault status value.

■ Option Compatibility

A limited number of options may be simultaneously connected to the drive depending on the type of option. Refer to [Table 31](#) for more information. More details can be found in the Options and Peripheral Devices chapter of the drive Technical Manual.

Table 31 Option Installation Compatibility

| Option | Connector | Number of Possible Options |
|--|-------------|----------------------------|
| SI-C3, SI-N3, SI-P3, SI-S3, SI-EP3, SI-EN3, SI-EM3 <1> | CN5-A | 1 |
| PG-B3, PG-X3 | CN5-B, C | 2 <2> |
| DO-A3, AO-A3, AI-A3, DI-A3 | CN5-A, B, C | 1 |

<1> When installed in CN5-A, the AI-A3 and DI-A3 options can be used to set the frequency reference or replace the drive analog inputs with higher resolution. When installed in CN5-B or CN5-C, these options can only be used for monitoring; their input levels will be displayed in U1-17 or U1-21 to U1-23.

<2> Use the CN5-C connector when connecting only one option to the drive; use both CN5-B and CN5-C when connecting two options.

11 Specifications

Table 32 Option Specifications

| Item | Specification |
|--------------------------|---|
| Model | SI-EP3 option |
| Option Conformance | Passed PROFINET Conformance Class A |
| Connector Type | Dual RJ45 8-pin Shielded Twisted Pair Cat 5e cable |
| Physical Layer Type | Isolated Physical Layer TCP Protocol Transformer Isolated |
| IP Address Setting | Programmable from drive keypad or network |
| Communication Speed | Programmable from drive keypad or network: 10/100 Mbps, auto-negotiate. |
| Number of Connections | 1 PLC connection, 1 supervisor connection, 2 web page connections |
| Duplex Mode | Half-forced, Auto-negotiate, Full-forced |
| Address Startup Mode | Static, DCP |
| Ambient Temperature | -10 °C to +50 °C |
| Humidity | Up to 95% RH (no condensation) |
| Storage Temperature | -20 °C to +60 °C (allowed for short-term transport of the product) |
| Area of Use | Indoor (free of corrosive gas, airborne particles, etc.) |
| Altitude | Up to 1000 m |
| PROFINET Functions | PROFINET IO with PROFIdrive profile Configurable I/O in cyclic messages Drive diagnostic alarms I&M0 |
| IEC Overvoltage Category | Intended for use in "Overvoltage Category II" as specified in IEC 60664-1 |

◆ Revision History

Revision dates and manual numbers appear on the bottom of the back cover.

MANUAL NO. SIEP YEACOM 07A
Major revision letter

Published in U.S.A. February 2011 11-02
Date of publication Date of original publication
Minor revision number

| Date of Publication | Revision Number | Section | Revised Content |
|---------------------|-----------------|---------|-----------------|
| February 2011 | - | - | First edition |

YASKAWA AC Drive1000-Series Option

PROFINET

Technical Manual

YASKAWA AMERICA, INC.

2121 Norman Drive South, Waukegan, IL 60085, U.S.A.
Phone: (800) YASKAWA (927-5292) or 1-847-887-7000 Fax: 1-847-887-7310
<http://www.yaskawa.com>

YASKAWA ELÉTRICO DO BRASIL LTDA.

Avenda Fagundes Filho, 620 Bairro Saude, São Paulo, SP04304-000, Brasil
Phone: 55-11-3585-1100 Fax: 55-11-5581-8795
<http://www.yaskawa.com.br>



YASKAWA AMERICA, INC.

In the event that the end user of this product is to be the military and said product is to be employed in any weapons systems or the manufacture thereof, the export will fall under the relevant regulations as stipulated in the Foreign Exchange and Foreign Trade Regulations. Therefore, be sure to follow all procedures and submit all relevant documentation according to any and all rules, regulations and laws that may apply.

Specifications are subject to change without notice for ongoing product modifications and improvements.

© 2011 YASKAWA AMERICA, INC. All rights reserved.

MANUAL NO. SIEP YEACOM 07

Published in U.S.A. Feb 2011 11-02 -0