



YASKAWA

# YASKAWA AC Drive-V1000 Option **PROFIBUS-DP** **Technical Manual**

Type SI-P3/V

To properly use the product, read this manual thoroughly and retain for easy reference, inspection, and maintenance. Ensure the end user receives this manual.

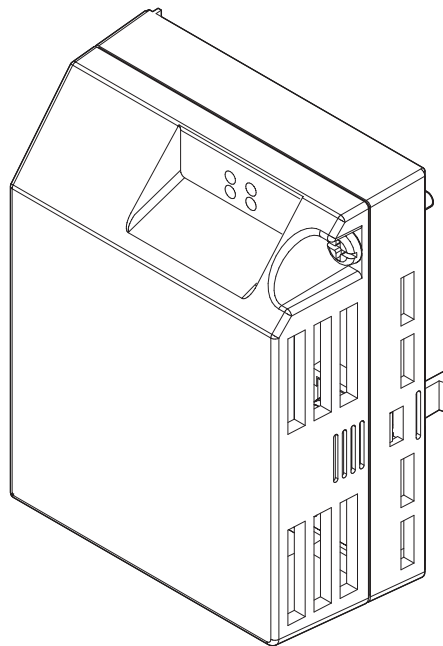



# Table of Contents

---

<b>1 PREFACE AND SAFETY</b> .....	<b>2</b>
<b>2 PRODUCT OVERVIEW</b> .....	<b>5</b>
<b>3 RECEIVING</b> .....	<b>6</b>
<b>4 PROFIBUS-DP OPTION COMPONENTS</b> .....	<b>7</b>
<b>5 INSTALLATION PROCEDURE</b> .....	<b>9</b>
<b>6 PROFIBUS-DP OPTION DRIVE PARAMETERS</b> .....	<b>13</b>
<b>7 TROUBLESHOOTING</b> .....	<b>14</b>
<b>8 CONVENTIONAL FORMATS</b> .....	<b>16</b>
<b>9 PARAMETER PROCESS DATA OBJECT FORMATS</b> .....	<b>34</b>
<b>10 SPECIFICATIONS</b> .....	<b>43</b>

Copyright © 2007 YASKAWA ELECTRIC CORPORATION

All rights reserved. No part of this publication may be reproduced, stored in a retrieval system, or transmitted, in any form or by any means, mechanical, electronic, photocopying, recording, or otherwise, without the prior written permission of Yaskawa. No patent liability is assumed with respect to the use of the information contained herein. Moreover, because Yaskawa is constantly striving to improve its high-quality products, the information contained in this manual is subject to change without notice. Every precaution has been taken in the preparation of this manual. Yaskawa assumes no responsibility for errors or omissions. Neither is any liability assumed for damages resulting from the use of the information contained in this publication.

# 1 Preface and Safety

Yaskawa manufactures products used as components in a wide variety of industrial systems and equipment. The selection and application of Yaskawa products remain the responsibility of the equipment manufacturer or end user. Yaskawa accepts no responsibility for the way its products are incorporated into the final system design. Under no circumstances should any Yaskawa product be incorporated into any product or design as the exclusive or sole safety control. Without exception, all controls should be designed to detect faults dynamically and fail safely under all circumstances. All systems or equipment designed to incorporate a product manufactured by Yaskawa must be supplied to the end user with appropriate warnings and instructions as to the safe use and operation of that part. Any warnings provided by Yaskawa must be promptly provided to the end user. Yaskawa offers an express warranty only as to the quality of its products in conforming to standards and specifications published in the Yaskawa manual. **NO OTHER WARRANTY, EXPRESS OR IMPLIED, IS OFFERED.** Yaskawa assumes no liability for any personal injury, property damage, losses, or claims arising from misapplication of its products.

## ◆ Applicable Documentation

The following manuals are available for the PROFIBUS-DP Option:

### Option Unit

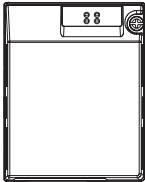
	Yaskawa AC Drive -V1000 Option PROFIBUS-DP Installation Manual	
	Read this manual first. The installation manual is packaged with the PROFIBUS-DP Option and contains a basic overview of wiring, settings, functions, and fault diagnoses.	
	Yaskawa AC Drive -V1000 Option PROFIBUS-DP Technical Manual	
	The technical manual contains detailed information and command registers. To obtain the technical manual access these sites: U.S.: <a href="http://www.yaskawa.com">http://www.yaskawa.com</a> Europe: <a href="http://www.yaskawa.eu.com">http://www.yaskawa.eu.com</a> Japan: <a href="https://www.e-mechatronics.com">https://www.e-mechatronics.com</a> Other areas: contact a Yaskawa representative.	

### Yaskawa Drive

	Yaskawa AC Drive-V1000 Installation & Start-Up Manual	To obtain instruction manuals for Yaskawa products access these sites: U.S.: <a href="http://www.yaskawa.com">http://www.yaskawa.com</a> Europe: <a href="http://www.yaskawa.eu.com">http://www.yaskawa.eu.com</a> Japan: <a href="https://www.e-mechatronics.com">https://www.e-mechatronics.com</a> Other areas: contact a Yaskawa representative.
	Yaskawa AC Drive-V1000 Technical Manual	
	Yaskawa AC Drive-V1000 Quick Start Guide	
		For questions, contact the local Yaskawa sales office or the nearest Yaskawa representative.

## ◆ Terms

**Note:** Indicates a supplement or precaution that does not cause drive damage.

Drive: Yaskawa AC Drive -V1000 Series  
PROFIBUS Option: Yaskawa AC Drive -V1000 Option PROFIBUS-DP

## ◆ Registered Trademarks

- PROFIBUS-DP is a registered trademark of PROFIBUS International.
- Other company names and product names listed in this manual are registered trademarks of those companies.

## ◆ Supplemental Safety Information

Read and understand this manual before installing, operating, or servicing this option unit. The option unit must be installed according to this manual and local codes.

The following conventions are used to indicate safety messages in this manual. Failure to heed these messages could result in serious or possibly even fatal injury or damage to the products or to related equipment and systems.

### DANGER

Indicates a hazardous situation, which, if not avoided, will result in death or serious injury.

### WARNING

Indicates a hazardous situation, which, if not avoided, could result in death or serious injury.

### CAUTION

Indicates a hazardous situation, which, if not avoided, could result in minor or moderate injury.

### NOTICE

Indicates an equipment damage message.

## ■ General Safety

### General Precautions

- The diagrams in this section may include option units and drives without covers or safety shields to illustrate details. Be sure to reinstall covers or shields before operating any devices. The option board should be used according to the instructions described in this manual.
- Any illustrations, photographs, or examples used in this manual are provided as examples only and may not apply to all products to which this manual is applicable.
- The products and specifications described in this manual or the content and presentation of the manual may be changed without notice to improve the product and/or the manual.
- When ordering a new copy of the manual due to damage or loss, contact your Yaskawa representative or the nearest Yaskawa sales office and provide the manual number shown on the front cover.

### **⚠ DANGER**

#### Heed the safety messages in this manual.

Failure to comply will result in death or serious injury.

The operating company is responsible for any injuries or equipment damage resulting from failure to heed the warnings in this manual.

### NOTICE

#### Do not expose the drive to halogen group disinfectants.

Failure to comply may cause damage to the electrical components in the option unit.

Do not pack the drive in wooden materials that have been fumigated or sterilized.

Do not sterilize the entire package after the product is packed.

## ■ Option Unit Label Warnings

Warning information is displayed on the option unit as shown in the figure below. Follow all warnings and safety instructions when using the product.

When using the drive in an area that may require displaying warning information in Japanese or Chinese, a sticker is provided with the PROFIBUS-DP Option. This sticker can be placed over the English and French warnings on the front of the PROFIBUS-DP Option.

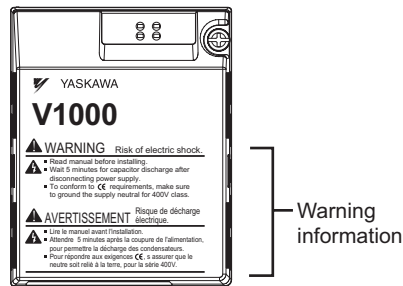

## ■ Warning Contents

### **⚠ WARNING** Risk of electric shock.

- Read manual before installing.
- Wait 5 minutes for capacitor discharge after disconnecting power supply.
- To conform to **CE** requirements, make sure to ground the supply neutral for 400V class.

### **⚠ AVERTISSEMENT** Risque de décharge électrique.

- Lire le manuel avant l'installation.
- Attendre 5 minutes après la coupure de l'alimentation, pour permettre la décharge des condensateurs.
- Pour répondre aux exigences **CE**, s'assurer que le neutre soit relié à la terre, pour la série 400V.

## 2 Product Overview

### ◆ About This Product

PROFIBUS is an open digital communication system supporting a wide range of fast, time-critical applications.

PROFIBUS-DP (Decentral Periphery) is one of the three PROFIBUS variants. DP is dedicated to fast data communication between systems and peripherals at a field level. This PROFIBUS-DP Option connects a drive to a field network using the PROFIBUS-DP protocol.

PROFIBUS-DP is included into the European Fieldbus Standard EN 50170.

The network is primarily used in process and factory automation.

By installing the PROFIBUS-DP Option to a drive, it is possible to do the followings from a PROFIBUS-DP master device:

- operate the drive
- monitor the operation status of the drive
- change parameter settings

### ◆ Applicable Models

The PROFIBUS-DP Option can be used with the drive models in [Table 1](#).

**Table 1 Applicable Models**

Drive	Software Version*
CIMR-V□□A□□□□BA□	1010 or later
CIMR-V□□A□□□□FA□	1010 or later
CIMR-V□□A□□□□JA□	1010 or later

\* See "PRG" on the drive nameplate for the software version number.

**Note:** The drive cannot be initialized (A1-03) using PROFIBUS-DP when running software version 1010.

**Note:** When b1-01 = 3 and/or b1-02 = 3 are selected and the communication option is not installed, V1000 detects oPE07 instead of oPE05 with software version 1010.

### 3 Receiving

Please perform the following tasks after receiving the PROFIBUS-DP Option:

- Inspect the PROFIBUS-DP Option for damage.  
If the PROFIBUS-DP Option appears damaged upon receipt, contact the shipper immediately.
- Verify receipt of the correct model by checking the information on the PCB (see Figure 1).
- If you have received the wrong model or the PROFIBUS-DP Option does not function properly, contact your supplier.

#### ◆ Contents and Packaging

Table 2 Contents of Package

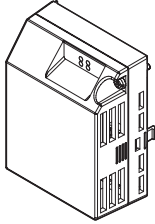
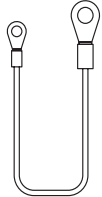
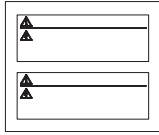
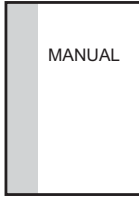
Description:	Option Unit	Ground Cables	Warning Labels	Installation Manual
-				
Quantity:	1	4	1	1

#### ◆ Tool Requirements

A Phillips screwdriver (for screw size\* #1 or #2, U.S. standard size) is required to install the PROFIBUS-DP Option.

\* Screw sizes vary by drive capacity. Select a screwdriver that matches the drive capacity.

**Note:** Tools required to prepare PROFIBUS cables for wiring are not listed in this manual.

## 4 PROFIBUS-DP Option Components

### ◆ PROFIBUS-DP Option

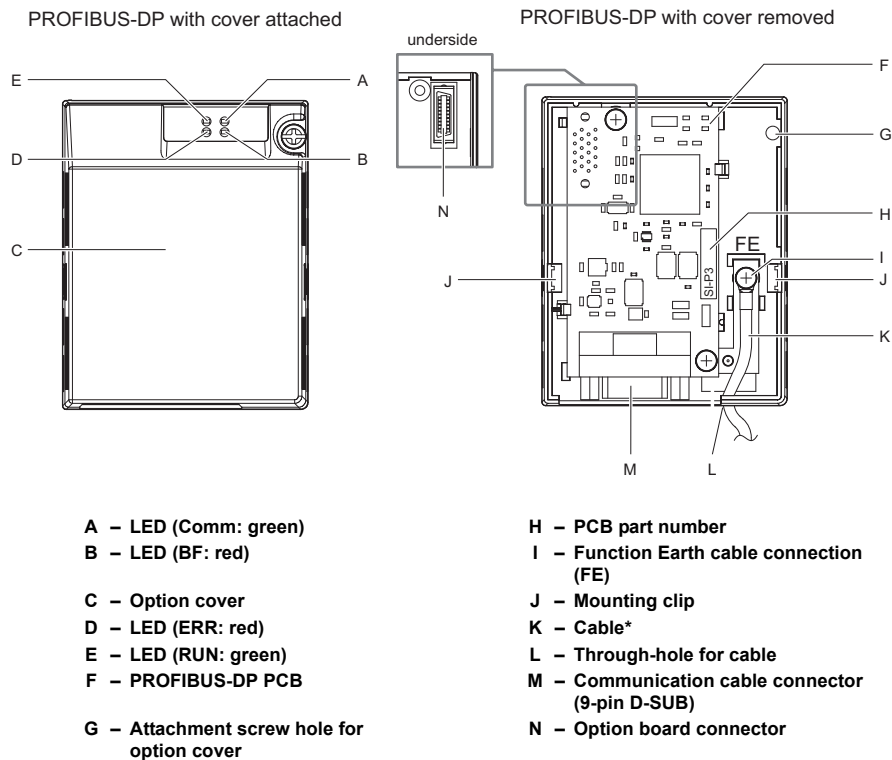

Figure 1 Option Unit

\* Cables are not connected to the PROFIBUS-DP Option and are packaged separately in the box.

Note: For details on the LEDs, [Refer to PROFIBUS-DP Option LED Display on page 8.](#)

### ◆ Dimensions

The installed PROFIBUS-DP Option adds 27 mm (1.06 in.) to the total depth of the drive.

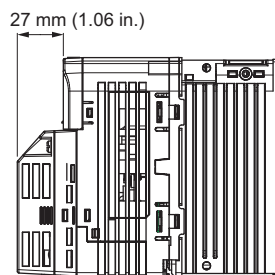

Figure 2 Dimensions

### ◆ Communication connector

The communication connector is a 9-pin D-SUB board-mounted connection. This connector is the connection point of the PROFIBUS network communication cable to the SI-P3/V PROFIBUS-DP Option.

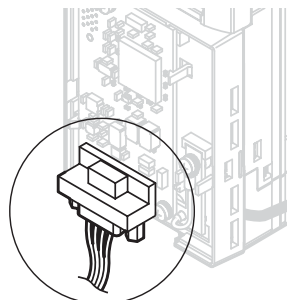
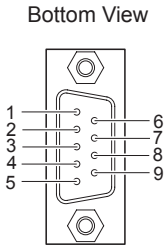

Figure 3 Communication connector location



Table 3 Communication connector (9-pin D-SUB)

PROFIBUS Connector	Pin	Signal	Description
	1	Shield	Connected to the metal-shell (no direct FG-connection)
	2	-	-
	3	RxD/TxD-P	Receive/Transmit data; line B (red)
	4	CNTR-P	Control signal for repeaters (direction control)
	5	DGND	Data ground (reference voltage to VP)
	6	VP	Power supply output for bus termination (+5V, greater than or equal to 10 mA)
	7	-	-
	8	RxD/TxD-N	Receive/Transmit data; line A (green)
	9	-	-

◆ PROFIBUS-DP Option LED Display

Table 4 LED Display

LED	Display		Communication Status	Meaning
	Color	Status		
RUN (Power)	Green	ON	Power is on	Power is being properly supplied to SI-P3/V, and SI-P3/V has completed its hardware self-diagnostics check
		OFF	Power is off	<ul style="list-style-type: none"> <li>The drive has no power supply</li> <li>SI-P3/V and drive are not connected properly and/or there is no power supplied to the SI-P3/V</li> </ul>
ERR (Option Error)	Red	ON	SI-P3/V error	Self-diagnostics error occurred in the SI-P3/V
		Flashing	Drive connection error	Connection error between SI-P3/V and drive. This includes node address setting errors to parameter F6-30 on the drive side
		OFF	No error is present	No error or the power supply is off. Assuming the power is supplied, this LED will remain off provided that there are no problems with the communication settings for the PROFIBUS-DP Option
COMM (Communication Status)	Green	ON	Communication connected	Normal send/receive between SI-P3/V and PROFIBUS-DP master
		OFF	No data exchange	There is a problem establishing communication between SI-P3/V and the PROFIBUS-DP master
BF (PROFIBUS-DP Error)	Red	ON	Waiting for communication procedure setting	PROFIBUS-DP master is initializing parameters or is online
		Flashing	Communication setting error	Communication parameter error from PROFIBUS-DP master
		OFF	No error is present	No error or the power supply is off. Assuming the power is supplied, this LED will remain off provided that there are no problems with the communication settings from the PROFIBUS-DP master

Table 5 Understanding LED Display

LED				Communication Status	Possible Cause	Solution
RUN	ERR	COMM	BF			
×	×	×	×	No power.	<ul style="list-style-type: none"> <li>The drive has no power.</li> <li>SI-P3/V is not properly connected to the drive, and therefore is not receiving enough power.</li> </ul>	<ul style="list-style-type: none"> <li>Check all wiring to the drive, then turn the power on.</li> <li>Shut the drive off and see if the PROFIBUS-DP Option is connected properly. Turn the power back on again.</li> </ul>
○	×	×	×	<ul style="list-style-type: none"> <li>Checking connection with the drive</li> <li>Waiting for data from the master.</li> </ul>	<ul style="list-style-type: none"> <li>SI-P3/V is reading the node address or parameter configuration</li> <li>Waiting for initial input data from master device.</li> </ul>	-
×	○	×	×	SI-P3/V Self-diagnostics error	The PROFIBUS-DP Option is damaged.	Cycle power to the drive. If the LED status does not change, replace the PROFIBUS-DP Option.
×	□	×	×	Problem connecting to the drive.	<ul style="list-style-type: none"> <li>Problem initializing the drive and SI-P3/V</li> <li>Incorrect node address.</li> </ul>	<ul style="list-style-type: none"> <li>Cycle power to the drive. If the LED status does not change, replace the PROFIBUS-DP Option</li> <li>Check the node address setting in the drive (parameter F6-10).</li> </ul>
○	×	×	○	Waiting for data from the master device.	Waiting for data from the master device (Set_Parm_Message or Chk_Cfg_Message).	<ul style="list-style-type: none"> <li>Check the network settings in the master</li> <li>Make sure the master device is operating normally</li> <li>Check the terminal resistance settings on the data line</li> <li>Look for any problems with the data line, or if the connector</li> <li>See if the data line connected properly to the drive's main circuit.</li> </ul>
○	×	×	□	Data is incorrect or PROFIBUS-DP Option timed out waiting for data.	The communication procedure in the master is set incorrectly.	Check the communication procedure settings in the master.
○	×	○	×	Sending or receiving data.	-	-

○: On / □: Flashing / ×: Off

◆ Setting Node Address

Set drive parameter F6-30 to a node address (Range 0 to 125) unique to the network.

## 5 Installation Procedure

### ◆ Section Safety

#### DANGER

##### Electrical Shock Hazard

**Do not connect or disconnect wiring while the power is on.**

Failure to comply will result in death or serious injury.

Disconnect all power to the drive, wait at least five minutes after all indicators are off, measure the DC bus voltage to confirm safe level, and check for unsafe voltages before servicing to prevent electric shock. The internal capacitor remains charged even after the power supply is turned off. The charge indicator LED will extinguish when the DC bus voltage is below 50 Vdc.

#### WARNING

##### Electrical Shock Hazard

**Do not remove option board cover while the power is on.**

Failure to comply could result in death or serious injury.

The diagrams in this section may include option units and drives without covers or safety shields to show details. Be sure to reinstall covers or shields before operating any devices. The option board should be used according to the instructions described in this manual.

**Do not allow unqualified personnel to use equipment.**

Failure to comply could result in death or serious injury.

Maintenance, inspection, and replacement of parts must be performed only by authorized personnel familiar with installation, adjustment, and maintenance of this product.

**Do not use damaged wires, place excessive stress on wiring, or damage the wire insulation.**

Failure to comply could result in death or serious injury.

##### Fire Hazard

**Tighten all terminal screws to the specified tightening torque.**

Loose electrical connections could result in death or serious injury by fire due to overheating of electrical connections.

#### NOTICE

##### Damage to Equipment

**Observe proper electrostatic discharge procedures (ESD) when handling the option unit, drive, and circuit boards.**

Failure to comply may result in ESD damage to circuitry.

**Never shut the power off while the drive is outputting voltage.**

Failure to comply may cause the application to operate incorrectly or damage the drive.

**Do not operate damaged equipment.**

Failure to comply may cause further damage to the equipment.

Do not connect or operate any equipment with visible damage or missing parts.

**Do not use unshielded cable for control wiring.**

Failure to comply may cause electrical interference resulting in poor system performance.

Use shielded twisted-pair wires and ground the shield to the ground terminal of the drive.

**Properly connect all pins and connectors.**

Failure to comply may prevent proper operation and possibly damage equipment.

**Check wiring to ensure that all connections are correct after installing the option unit and connecting any other devices.**

Failure to comply may result in damage to the option unit.

◆ Wiring Diagram

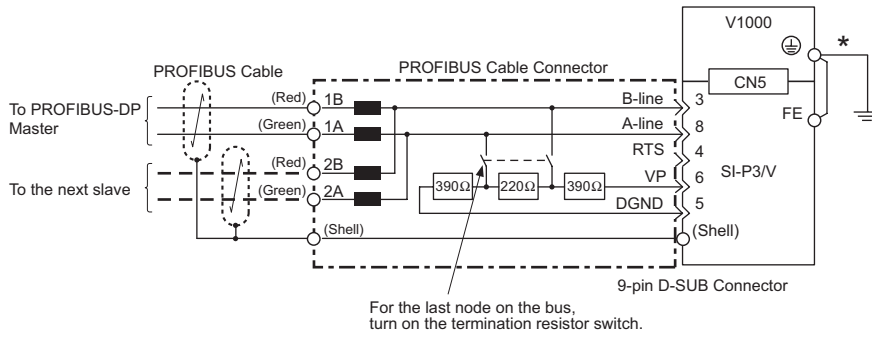

Figure 4 Wiring Diagram

\* The FE terminal on the PROFIBUS-DP Option is fitted with a ground cable that should be connected to the ground terminal on the drive.

■ PROFIBUS-DP Termination

The PROFIBUS-DP Option PCB is not supplied with a built-in network terminating resistor. A 9-pin D-SUB connector with a built-in terminating resistor and inductor should be used. Ensure that the terminating resistors are only closed at the two segment ends and nowhere else. Any additional terminations can cause corruption of the PROFIBUS signals and network malfunction.

In PROFIBUS 9-pin D-SUB connectors, the switch for the bus termination often has the second function of isolating the outgoing cable from the connector to the next slave. It is essential that only the incoming cable entry is used on connectors located at the ends of the PROFIBUS segment. If an incorrect cable entry method is used, neither the PROFIBUS device nor the termination network will be connected to the network segment. Most connectors mark incoming and outgoing cable entries with arrows.

Terminating resistors without inductors as shown in [Figure 6](#) can only be used for baud rates below 1.5 Mbps. 1.5 Mbps and higher baud rates require termination with resistors and inductors like shown in [Figure 4](#).

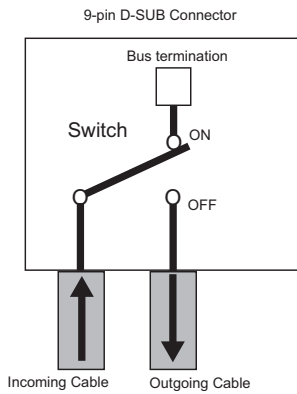

Figure 5 PROFIBUS Cable Connection with Termination Resistors

Bus termination ON = incoming and outgoing cables not connected.
Bus termination OFF = incoming and outgoing cables connected.

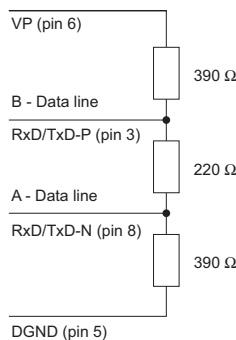

Figure 6 Cable Termination of the PROFIBUS-DP Option Cable to EN50170 (pin numbers for a 9-pin D-SUB connector)

◆ Prior to Installing the Option Unit

Prior to installing the PROFIBUS-DP Option, wire the drive and make necessary connections to the drive terminals. Refer to the V1000 Installation and Start-Up Manual for information on wiring and connecting the drive. Verify that the drive runs normally without the option installed.

◆ Installing the PROFIBUS-DP Option

Remove the front cover of the drive before installing the PROFIBUS-DP Option. Wire the drive terminals first, as they are obscured by the PROFIBUS-DP Option. Follow the directions below for proper installation.

**Note:** Run the drive before installing the PROFIBUS-DP Option to ensure that the drive or drive connections are not faulty.

1. Switch off the power supply to the drive.

**DANGER! Electrical Shock Hazard** - Do not connect or disconnect wiring while the power is on. Failure to comply will result in death or serious injury. Before installing the PROFIBUS-DP Option, disconnect all power to the drive. The internal capacitor remains charged even after the power supply is turned off. The charge indicator LED will extinguish when the DC bus voltage is below 50 Vdc. To prevent electric shock, wait at least five minutes after all indicators are off and measure the DC bus voltage level to confirm safe level.

2. Remove the front cover. The original drive front cover may be discarded because it will be replaced by the PROFIBUS-DP Option cover in step 7.

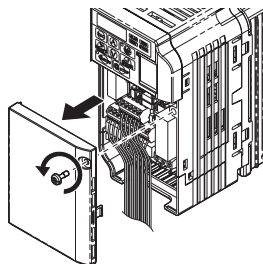

**Figure 7 Remove Front Cover**

3. Remove the bottom cover and connect the PROFIBUS-DP Option ground cable to the ground terminal.

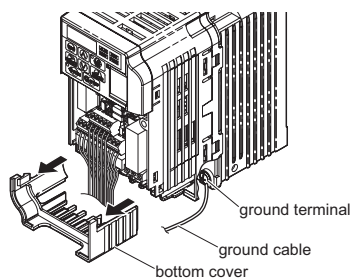

**Figure 8 Connect Ground Cable**

**Note:** The four different ground cables packaged with the PROFIBUS-DP Option connect to different models. Select the proper ground cable from the PROFIBUS-DP Option kit depending on drive size.

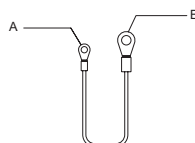

- A – Option unit connection: screw size = M3
- B – Drive-side connection: screw size = M3.5 to M6

**Figure 9 Ground Cable**

**Note: Cover removal for certain larger models with a Terminal Cover:**

- Single-Phase 200 V Class: CIMR-V□BA0006 to BA0018
- Three-Phase 200 V Class: CIMR-V□2A0008 to 2A0069
- Three-Phase 400 V Class: All models

Remove the terminal cover before removing the bottom cover to install the PROFIBUS-DP Option. Replace the terminal cover after wiring the PROFIBUS-DP Option.

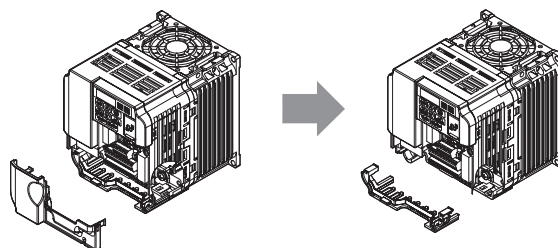

**Figure 10 Models with Terminal Cover**

4. Reattach the bottom cover.
5. Connect the PROFIBUS-DP Option to the drive. Properly secure the tabs on the left and right sides of the PROFIBUS-DP Option to the drive case.

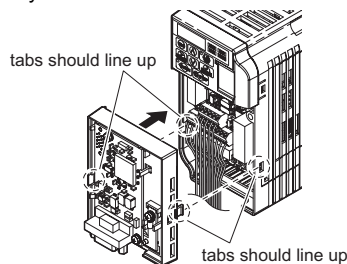

**Figure 11 Attach PROFIBUS-DP Option**

6. Connect the ground cable from the drive ground terminal to the PROFIBUS-DP Option ground. When wiring the PROFIBUS-DP Option, pass the

## 5 Installation Procedure

ground cable through the inside of the drive bottom cover, then pass the ground cable into the through-hole at the front of the PROFIBUS-DP Option.

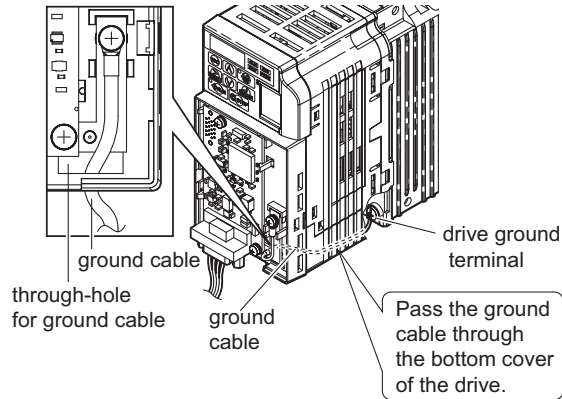

Figure 12 Ground Cable Connection

7. Attach the PROFIBUS-DP Option cover to the front of the PROFIBUS-DP Option.

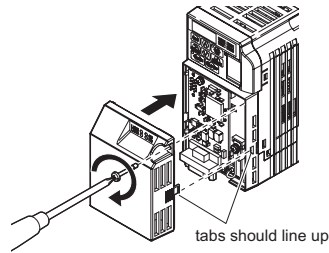

Figure 13 Attach Cover

**Note:** When using the drive in an area that may require displaying warning information in Japanese or Chinese, a sticker has been provided with the PROFIBUS-DP Option. This sticker can be placed over the English and French warnings on the front of the PROFIBUS-DP Option.

### ◆ Communication Cable Specifications

To ensure proper performance, Yaskawa recommends using PROFIBUS-DP-dedicated cables that fulfill the specifications in [Table 6](#). For more information on cables, refer to the PROFIBUS-DP website at <http://www.profibus.com>.

#### ■ Cable Requirements

Table 6 Communication Cable Requirements

Condition	Specifications
Impedance	135 to 165 $\Omega$ at a frequency of (3 to 20 MHz)
Capacity	30 pF/m maximum
Loop Resistance	110 $\Omega$ /km maximum
Core Cross-Section	0.34 mm <sup>2</sup> minimum
Core Diameter	0.64 mm minimum

#### ■ Cable Length

Communication speed determines maximum permissible cable length. [Table 7](#) shows the specifications for Type A bus cables.

Table 7 Cable Length

Communication speed (kbps)	Distance per segment (m)
9.6	1200
19.2	1200
45.45	1200
93.75	1200
187.5	1000

Communication speed (kbps)	Distance per segment (m)
500	400
1500	200
3000	100
6000	100
12000	100

### ◆ GSD Files

For easy network implementation of drives equipped with an SI-P3/V, a GSD file can be obtained from:

U.S.: <http://www.yaskawa.com>

Europe: <http://www.yaskawa.eu.com>

Japan: <https://www.e-mechatronics.com>

Other areas: contact a Yaskawa representative

## 6 PROFIBUS-DP Option Drive Parameters

Confirm the proper setting of all parameters in [Table 8](#) before starting network parameters.

**Table 8 Parameter Settings**

No.	Name	Description	Default
b1-01	Frequency Reference Selection *1 *2	Selects the frequency reference input source 0: Operator - Digital preset speed d1-01 to d1-17 1: Terminals - Analog input terminal A1 or A2 2: MEMOBUS/Modbus communications 3: Option PCB 4: Pulse Input (Terminal RP)	1
b1-02	Run Command Selection *1 *2	Selects the run command input source 0: Digital Operator - RUN and STOP keys 1: Digital input terminals S1 to S7 2: MEMOBUS/Modbus communications 3: Option PCB	1
F6-01	Operation Selection after Communications Error	Determines drive response when a bUS error is detected during communications with the PROFIBUS-DP Option 0: Ramp to Stop 1: Coast to Stop 2: Fast-Stop 3: Alarm Only	1
F6-02	External Fault Detection Conditions (EF0)	Sets the condition for external fault detection (EF0) 0: Always detected 1: Detected only during operation	0
F6-03	Stopping Method for External Fault from Communication Option Board	Determines drive response for external fault input (EF0) detection during PROFIBUS communication 0: Ramp to Stop 1: Coast to Stop 2: Fast-Stop 3: Alarm Only *3	1
F6-04	bUS Error Detection Delay Time	Set the maximum time the drive should wait for a communication error to occur (bUS) Range 0.00 to 5.00 s	0.05
F6-30	Node Address *4	0 to 125	0
F6-31	Clear Mode Selection	Selects the action to take when a "Clear Mode" command is received 0: Resets back to 0 1: Maintains the previous value	0
F6-32	PROFIBUS Map Selection	0: PPO Type 1: Conventional	0

\* 1. To start and stop the drive through the PROFIBUS-DP network, set b1-02 to "3". To control the frequency reference of the drive via the PROFIBUS-DP network, set b1-01 to "3".

\* 2. When b1-01 = 3 and/or b1-02 = 3 are selected and the communication option is not installed, V1000 detects oPE07 instead of oPE05 with software version 1010.

\* 3. If F6-03 is set to 3, then the drive will continue to operate when an EF0 fault is detected. Take proper safety measures, such as installing an emergency stop switch.

\* 4. All node addresses must be unique. Node addresses 0, 1, and 2 are typically reserved for control, maintenance, and diagnostic equipment. The ERR light will illuminate when 0 or greater than 125 is entered.

## 7 Troubleshooting

### ◆ Drive-Side Error Codes

Drive-side error codes appear on the drive LED operator. Causes of the errors and corrective actions are listed in [Table 9](#). For additional error codes that may appear on the LED operator screen, refer to the instruction manual for the drive.

#### ■ Faults

bUS (PROFIBUS-DP Option Communication Error) and EF0 (External Fault Input from the PROFIBUS-DP Option) may appear as an alarm or a fault. When a fault occurs, the digital operator LEDs remain lit. When an alarm occurs, the digital operator LEDs flash and the “ALM” light illuminates.

If communication stops while the drive is running, check the following items to resolve the fault:

- Is the PROFIBUS-DP Option properly installed?
- Is the communication line properly connected to the PROFIBUS-DP Option? Is it loose?
- Is the controller program working? Has the controller CPU stopped?
- Did a momentary power loss interrupt communications?

**Table 9 Fault Display and Possible Solutions**

LED Operator Display		Fault Name
<i>bUS</i>	bUS	PROFIBUS-DP Option Communication Error
		After establishing initial communication, the connection was lost. Only detected when the run command frequency reference is assigned to the option.
Cause		Possible Solution
Master controller (PLC) has stopped communicating. Communication cable is not connected properly.		Check for faulty wiring. ⇒ Correct any wiring problems.
A data error occurred due to noise.		Check the various options available to minimize the effects of noise. ⇒ Take steps to counteract noise in the control circuit wiring, main circuit lines, and ground wiring. ⇒ If a magnetic contactor is identified as a source of noise, install a surge absorber to the contactor coil. ⇒ Use cables recommended by Yaskawa, or another type of shielded line. Ground the shield on the controller side and on the PROFIBUS-DP Option side.
PROFIBUS-DP Option is damaged.		⇒ If there are no problems with the wiring and the error continues to occur, replace the PROFIBUS-DP Option.
PROFIBUS-DP Option is not properly connected to the drive.		The connector pins on the PROFIBUS-DP Option are not properly seated with the connector pins on the drive. ⇒ Reinstall the PROFIBUS-DP Option

LED Operator Display		Fault Name
<i>EF0</i>	EF0	External Fault Input from PROFIBUS-DP Option
		The alarm function for an external device has been triggered.
Cause		Possible Solution
An external fault is being sent from the upper controller (PLC).		⇒ Remove the cause of the external fault. ⇒ Reset the external fault input from the upper controller (PLC) device.
Problem with the upper controller (PLC) program.		⇒ Check the program used by the upper controller (PLC) and make the appropriate corrections.

LED Operator Display		Fault Name
<i>oFA00</i>	oFA00	PROFIBUS-DP Option Fault (Port A)
		PROFIBUS-DP Option is not properly connected.
Cause		Possible Solution
Non-compatible option connected to the drive.		⇒ Connect an option that is compatible with the drive.

LED Operator Display		Fault Name
<i>oFA01</i>	oFA01	PROFIBUS-DP Option Fault (Port A)
		PROFIBUS-DP Option is not properly connected.
Cause		Possible Solution
Problem with the connectors between the drive and PROFIBUS-DP Option.		⇒ Turn the power off and check the connectors between the drive and PROFIBUS-DP Option.

LED Operator Display		Fault Name
<i>oFA03</i>	oFA03	PROFIBUS-DP Option Fault (Port A)
		PROFIBUS-DP Option self-diagnostics error.
Cause		Possible Solution
PROFIBUS-DP Option hardware fault.		⇒ Replace the PROFIBUS-DP Option. Contact Yaskawa for assistance.

LED Operator Display		Fault Name
oFA04	oFA04	PROFIBUS-DP Option Fault (Port A)
		PROFIBUS-DP Option Flash write mode
Cause		Possible Solution
PROFIBUS-DP Option hardware fault.		⇒ Replace the PROFIBUS-DP Option. Contact Yaskawa for assistance.

## ■ Alarms

**Table 10 Alarm Display**

LED Operator Display		Alarm Name
bb	bb	Baseblock Alarm
		<p>The drive output is disabled. "bb" will be displayed on the operator when the drive is set for control by PROFIBUS-DP and:</p> <ul style="list-style-type: none"> <li>• a conventional data format is used and the operation command bit F is set to 1.</li> <li>• a PPO type data format is used the the control word (STW) bit 3 is set to 0.</li> </ul> <p>To enable the drive set either of the bits depending on which data format is used.</p>



## 8 Conventional Formats

### ◆ Conventional Formats

The configuration tool of PROFIBUS-DP master sets the input and output data length of SI-P3/V from Extended Data 1 (32 bytes), Extended Data 2 (12 bytes), and Basic Data (6 bytes).

Conventional formats have two message types: High-speed I/O Data and MEMOBUS/Modbus message.

Set parameter F6-32 to “1” to use conventional formats.

#### ■ High-Speed I/O Data

High-speed I/O data is directly transferred to or from the drive and can control the drive. For example, when the drive is set for PROFIBUS-DP communications, the drive Run/Stop and Frequency Reference commands are typically transferred to the drive within 2 ms after being received by the option.

#### ■ MEMOBUS/Modbus Message

MEMOBUS/Modbus message data is transferred to the drive using MEMOBUS/Modbus messages. All drive parameters and data can be accessed through MEMOBUS/Modbus. Because the data in this message type is transferred to the drive after the SI-P3/V receives and edits it, more time is required to return the data to the master. The master must synchronize the timing of sending and receiving the data by handshaking.

#### ■ Memory Maps

The following memory maps show the I/O data bytes.

#### ■ Basic and Extended Register Maps

	Basic Data (6 bytes)	Extended Data 1 (32 bytes)	Extended Data 2 (12 bytes)
High-speed I/O Data	Bytes 0 to 5	Bytes 0 to 15	Bytes 0 to 3
MEMOBUS/Modbus Data	–	Bytes 16 to 31	Bytes 4 to 11

Table 11 Basic Data Register Map Detail

Output		Input	
Byte	Description	Byte	Description
0	Operation Command High Byte	0	Drive Status High Byte
1	Operation Command Low Byte	1	Drive Status Low Byte
2	Frequency Reference High Byte	2	Motor Speed High Byte* <sup>1</sup>
3	Frequency Reference Low Byte	3	Motor Speed Low Byte* <sup>1</sup>
4	Reserved	4	Output Current High Byte* <sup>2</sup>
5		5	Output Current High Byte* <sup>2</sup>

\* 1. Unit depends on the setting of o1-03 (Digital Operator Display Scaling). The register content is zero if the drive is set for V/f control.

\* 2. The unit is 0.01 A for drives set up to 11 kW in Heavy Duty or Normal Duty and 0.1 A for drives set up for 15 kW and above.

Table 12 and Table 15 specify the data transferred in the Extended I/O data exchange message.

Table 12 Extended Data 1 Register Map

Output		Input	
Byte	Description	Byte	Description
0	Operation Command High Byte	0	Drive Status High Byte
1	Operation Command Low Byte	1	Drive Status Low Byte
2	Frequency Reference High Byte	2	Motor Speed High Byte* <sup>3</sup>
3	Frequency Reference Low Byte	3	Motor Speed Low Byte* <sup>3</sup>
4	Reserved	4	Torque Reference Monitor High Byte* <sup>4</sup>
5		5	Torque Reference Monitor Low Byte* <sup>4</sup>
6		6	Reserved
7		7	Reserved
8	Reserved	8	Frequency Reference High Byte
9		9	Frequency Reference Low Byte
10	Analog Output Channel 1 High Byte* <sup>1</sup>	10	Output Frequency High Byte
11	Analog Output Channel 1 Low Byte* <sup>1</sup>	11	Output Frequency Low Byte
12	Reserved	12	Output Current High Byte* <sup>5</sup>
13		13	Output Current Low Byte* <sup>5</sup>
14	Digital Output High Byte* <sup>2</sup>	14	Analog Input Channel 1 High Byte
15	Digital Output Low Byte* <sup>2</sup>	15	Analog Input Channel 1 Low Byte
16	MEMOBUS/Modbus Function Code	16	MEMOBUS/Modbus Function Code
17	MEMOBUS/Modbus Starting Register Address High Byte	17	MEMOBUS/Modbus Starting Register Address High Byte
18	MEMOBUS/Modbus Starting Register Address Low Byte	18	MEMOBUS/Modbus Starting Register Address Low Byte
19	MEMOBUS/Modbus Number of Data	19	MEMOBUS/Modbus Number of Data
20	MEMOBUS/Modbus Data 1 High Byte	20	MEMOBUS/Modbus Data 1 High Byte
21	MEMOBUS/Modbus Data 1 Low Byte	21	MEMOBUS/Modbus Data 1 Low Byte
22	MEMOBUS/Modbus Data 2 High Byte	22	MEMOBUS/Modbus Data 2 High Byte

Output		Input	
Byte	Description	Byte	Description
23	MEMOBUS/Modbus Data 2 Low Byte	23	MEMOBUS/Modbus Data 2 Low Byte
24	MEMOBUS/Modbus Data 3 High Byte	24	MEMOBUS/Modbus Data 3 High Byte
25	MEMOBUS/Modbus Data 3 Low Byte	25	MEMOBUS/Modbus Data 3 Low Byte
26	MEMOBUS/Modbus Data 4 High Byte	26	MEMOBUS/Modbus Data 4 High Byte
27	MEMOBUS/Modbus Data 4 Low Byte	27	MEMOBUS/Modbus Data 4 Low Byte
28	Reserved	28	Reserved
29		29	
30		30	
31	Handshaking Register	31	Handshake Register

- \* 1. To select drive analog output channel for communications, set H4-01 (Multi-Function Analog Output Terminal AM) to 31 (Not used)
- \* 2. Drive digital output ON/OFF during communications, set H2-01 (Terminal MA, MB and MC Function Selection (relay)), H2-02 (Terminal P1 Function Selection (open-collector)), and H2-03 (Terminal P2 Function Selection (open-collector)) to F.
- \* 3. Unit depends on the setting of o1-03 (Digital Operator Display Scaling). The register content is zero if the drive is set for V/f control.
- \* 4. Cannot be used when setting A1-02 (Control Method Selection) to 0 (V/f Control without PG).
- \* 5. The unit is 0.01 A for drives set up to 11 kW in Heavy Duty or Normal Duty and 0.1 A for drives set up for 15 kW and above.

Table 13 Operation Command

Command Signal	Description
0	H5-12 = 0: Forward Run/Stop, 1: FRUN H5-12 = 1: Run/Stop, 1: RUN
1	H5-12 = 0: Reverse Run/Stop, 1: RRUN H5-12 = 1: Forward/Reverse, 1: REV
2	Multi-function digital input command 3
3	Multi-function digital input command 4
4	Multi-function digital input command 5
5	Multi-function digital input command 6
6	Multi-function digital input command 7
7	Reserved
8	External Fault, 1: Fault (EF0)
9	Fault Reset, 1: Fault Reset
A	Reserved
B	
C	
D	
E	Fault Trace and Fault History Reset 1: Fault information is reset by raising edge of this bit.
F	Baseblock command 1: Ext Baseblock

Table 14 Drive Status: U1-12

Drive Status	Description
0	1: During run
1	1: During zero speed
2	1: During reverse run
3	1: During fault reset signal input
4	1: During speed agree
5	1: Drive ready
6	1: Alarm
7	1: Fault
8	1: During operation error (oPE□□)
9	1: During momentary power loss
A	1: NetCtrl status
B	1: MA-MB relay closed
C	1: Photocoupler output 1 closed
D	1: Photocoupler output 2 closed
E	1: Motor 2 selected
F	Reserved

The register exchanged in input byte 2, 3 in [Table 15](#) depends on the control method specified in parameter U1-04. If U1-04 = 0 or 5 (V/f mode or PM V/f mode), the output frequency register changes.

Table 15 Extended Data 2 Register Map

Output		Input	
Byte	Description	Byte	Description
0	Operation Command High Byte	0	Drive Status High Byte
1	Operation Command Low Byte	1	Drive Status Low Byte

## 8 Conventional Formats

Output		Input	
Byte	Description	Byte	Description
2	Frequency Reference High Byte	2	Motor Speed High Byte *1
3	Frequency Reference Low Byte	3	Motor Speed Low Byte *1
4	MEMOBUS/Modbus Function Code	4	MEMOBUS/Modbus Function Code
5	MEMOBUS/Modbus Starting Register Address High Byte	5	MEMOBUS/Modbus Starting Register Address High Byte
6	MEMOBUS/Modbus Starting Register Address Low Byte	6	MEMOBUS/Modbus Starting Register Address Low Byte
7	MEMOBUS/Modbus Data Length	7	MEMOBUS/Modbus Data Length
8	MEMOBUS/Modbus Data 1 High Byte	8	MEMOBUS/Modbus Data 1 High Byte
9	MEMOBUS/Modbus Data 1 Low Byte	9	MEMOBUS/Modbus Data 1 Low Byte
10	Reserved	10	Reserved
11	Handshaking Register	11	Handshake Register

\* 1. Unit depends on the setting of o1-03 (Digital Operator Display Scaling). The register content is 0 if the drive is set for V/f control.

### ◆ MEMOBUS/Modbus Message Area

In this area, a MEMOBUS/Modbus message is transferred to the SI-P3/V unit, and the parameters in the drive can be set, read, and monitored. Up to four data items can be written or read at one time.

Because the SI-P3/V unit edits the MEMOBUS/Modbus message internally and transfers it to the drive after receiving the message, more time is required to return the message. Use the handshaking register to synchronize sending or receiving of the data between the PROFIBUS-DP master and the SI-P3/V unit. For details on the handshaking register, refer to [Handshaking Register on page 20](#).

Execute an Enter command to write a parameter to the drive. Execution of the Enter command validates the written data. For the details of the Enter command, refer to [Enter Command \(Write Only\) on page 41](#).

### ■ Configuration of MEMOBUS/Modbus Command Message

The following table shows the configuration of MEMOBUS/Modbus command messages when the Extended Data 1 is selected.

Table 16 MEMOBUS/Modbus Command Message

Byte	Name	Function	
16	Function code	MEMOBUS/Modbus command code: 03H: Read command (reading Drive internal data) 08H: Loop back 10H: Write command (writing data into the drive) Other codes: Not supported.	
17	Starting Resistor No.	Starting resistor No.	High Byte
18			Low Byte
19	Number of Data Items	Sets the number of bytes to read or write (only 2, 4, 6, or 8 allowed)	
20	Data 1*	Data word 1	High Byte
21			Low Byte
22	Data 2*	Data word 2	High Byte
23			Low Byte
24	Data 3*	Data word 3	High Byte
25			Low Byte
26	Data 4*	Data word 4	High Byte
27			Low Byte
28	Reserved	Reserved	
29			
30			
31	Handshaking Register	Refer to <a href="#">Handshaking Register on page 20</a> .	

\* Setting is needed only for the write command. Select 00H for the read command.

### ■ Configuration of MEMOBUS/Modbus Response Messages

The following table shows the configuration of MEMOBUS/Modbus response messages when the Extended Data 1 is selected.

Table 17 MEMOBUS/Modbus Response Messages

Byte	Name	Function	
16	Function code	MEMOBUS/Modbus response codes 00H: Waiting for response from drive 03H: Response to read operation 10H: Response to write operation 83H: Read command error 90H: Write command error Other codes: Not supported.	
17	Starting resistor No.	Starting resistor No.	High Byte
18			Low Byte
19	Number of data items	Write: Set double number of written data items Read: Set double number of read data items	
20	Data 1*	Data word 1	High Byte
21			Low Byte

Byte	Name	Function	
22	Data 2*	Data word 2	High Byte
23			Low Byte
24	Data 3*	Data word 3	High Byte
25			Low Byte
26	Data 4*	Data word 4	High Byte
27			Low Byte
28	Reserved		
29			
30			
31	Handshaking register	Refer to <a href="#">Handshaking Register on page 20</a> .	

\* Data is returned only for the read command.

If an error occurs, the SI-P3/V unit sets the MSB (Most Significant Bit) in the MEMOBUS/Modbus response code to 1 and returns the error response. The number of data items is set to 02H and one of the following error codes is written into the Low Byte of Data 1.

**Table 18 Error Descriptions**

Error Name	Error Code	Description
Function Code Error	01H	Something other than 03H or 10H is specified for the function code.
Incorrect Register No.	02H	Start register No. is greater than the setting of 600H. Unused register No. is specified.
Improper Number of Data Items	03H	The number of data items at write-in or read-out is outside the acceptable range setting of the parameter for writing in 2 to 8.
Incorrect Data Contents	21H	The setting of the parameter for writing in is beyond the upper or lower limit of the parameter. Parameter is incorrectly set at parameter write-in.
Incorrect Write-in	22H	A parameter is written during running. Enter command is written during running. Read-only data is written.
	23H	A parameter is written when the Drive is undervoltage (Uv). Enter command is written when the Drive is undervoltage (Uv).
	24H	A parameter is written while data is being stored.

#### ■ Parameter Settings Using MEMOBUS/Modbus Commands

The written or read data of each parameter is transferred in a hexadecimal value.

Negative values are expressed as a two complement.

Example 1: The frequency reference is 30Hz.

30 Hz/0.01 Hz = 3000 → BB8H

Example 2: -5% is assigned as the bias for terminal FM of multi-function analog output 1.

5/0.1 = 50 → 32H

Converted into a two complement → FFCEH

Example 3: 60.00 Hz is assigned for d1-01 (register No.: 0280H).

60.00Hz/0.01Hz = 6000 → 1770H

**Table 19 Parameter Settings Using MEMOBUS/Modbus Commands**

Byte	Name	Data		
		Command Message	Response Message	Response Message (at Fault) <sup>*2</sup>
16	Function code	10H	10H	90H
17	Starting Register No.	High Byte	02H	02H
18		Low Byte	80H	80H
19	Number of Data Items	02H	02H	02H
20	Data 1	High Byte	17H	00H
21		Low Byte	70H	00H
22	Data 2	High Byte	00H	00H
23		Low Byte	00H	00H
24	Data 3	High Byte	00H	00H
25		Low Byte	00H	00H
26	Data 4	High Byte	00H	00H
27		Low Byte	00H	00H
28	Reserved	00H	00H	00H
29		00H	00H	00H
30		00H	00H	00H
31	Handshaking Register <sup>*1</sup>	01H	01H	01H

\* 1. Depends on the status of the previous data.

\* 2. Depends on the status of the fault.

## 8 Conventional Formats

### ■ Handshaking Register

Handshaking is used to synchronize the timing of the sending or receiving of MEMOBUS/Modbus message data between the SI-P3/V unit and the PROFIBUS-DP master.

When the master toggles bit 7 of the handshaking register in the output data, the SI-P3/V starts to process the data in the MEMOBUS/Modbus registers. Ensure that the data in the MEMOBUS/Modbus registers is valid before toggling bit 7.

When the SI-P3/V toggles bit 7 of the handshaking register in the input data to the same value as handshake register bit 7 in the output data, the content of the input data MEMOBUS/Modbus registers is valid.

#### Handshaking Output Register

PROFIBUS-DP Master to SI-P3/V Unit

Bit 7	6	5	4	3	2	1	0
HS	-	-	-	-	-	-	INIT

Bit	Name	Function
7	HS	Handshaking bit. Used to synchronize the timing for sending or receiving data. Changes the status when a new command is transmitted. <b>Note:</b> This bit is cleared to 0 when the power supply is turned on or bit 0 of the handshake register (INIT) is set to 1.
1 to 6	-	Not used
0	INIT	Clears the handshaking bit to 0

#### Handshaking Input Register

SI-P3/V Unit to PROFIBUS-DP Master

Bit 7	6	5	4	3	2	1	0
HS	STATUS		WD			-	

Bit	Name	Function
7	HS	This bit is cleared to 0 when the power supply is turned ON or by initializing the handshake register in the output data. <b>Note:</b> Handshaking bit. Used to synchronize the timing for sending or receiving data. It is toggled to signal a new that message is present.
5 to 6	STATUS*	Status of the data exchange between the PROFIBUS-DP master and the drive. 00H: Idle 01H: SI-P3/V sends a MEMOBUS/Modbus command to the drives. 10H: SI-P3/V waits for a MEMOBUS/Modbus response from the drives. 11H: SI-P3/V receives a MEMOBUS/Modbus response from the drives.
1 to 4	WD*	Counter increases every 64 ms
0	-	Not used

\* STATUS and WD are for reference.

■ Example of Handshaking

Clear the handshaking register HS bit (bit 7) to 0 for the PLC program after turning on the power supply or after re-initializing. *Figure 14* describes the handshaking function. The arrow marks indicate whether the PROFIBUS-DP master or the SI-P3/V unit has the control for the protocol.

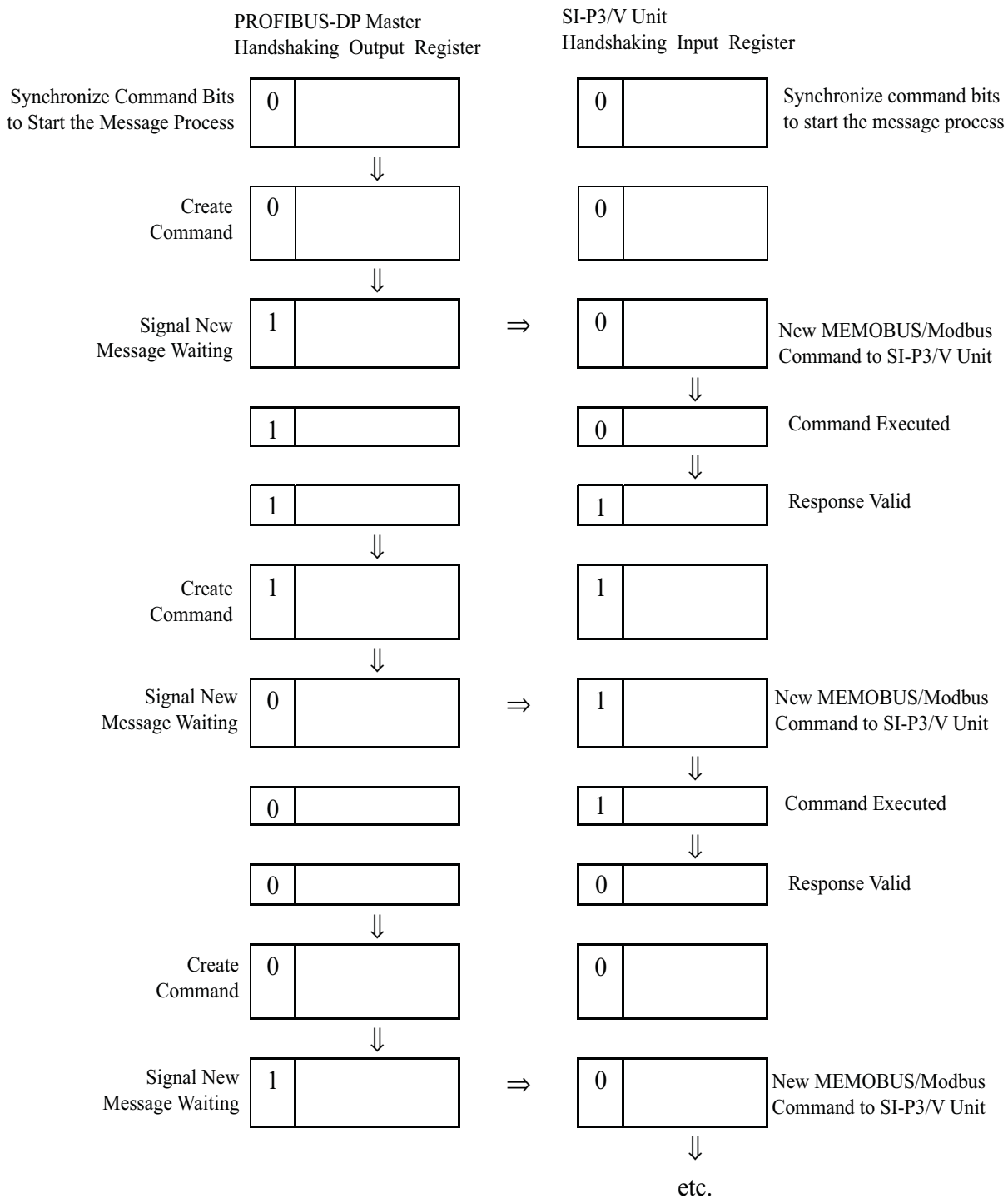

Figure 14 Example of Handshaking

■ Flow Chart

Figure 15 illustrates the handshaking function when using a MEMOBUS/Modbus message.

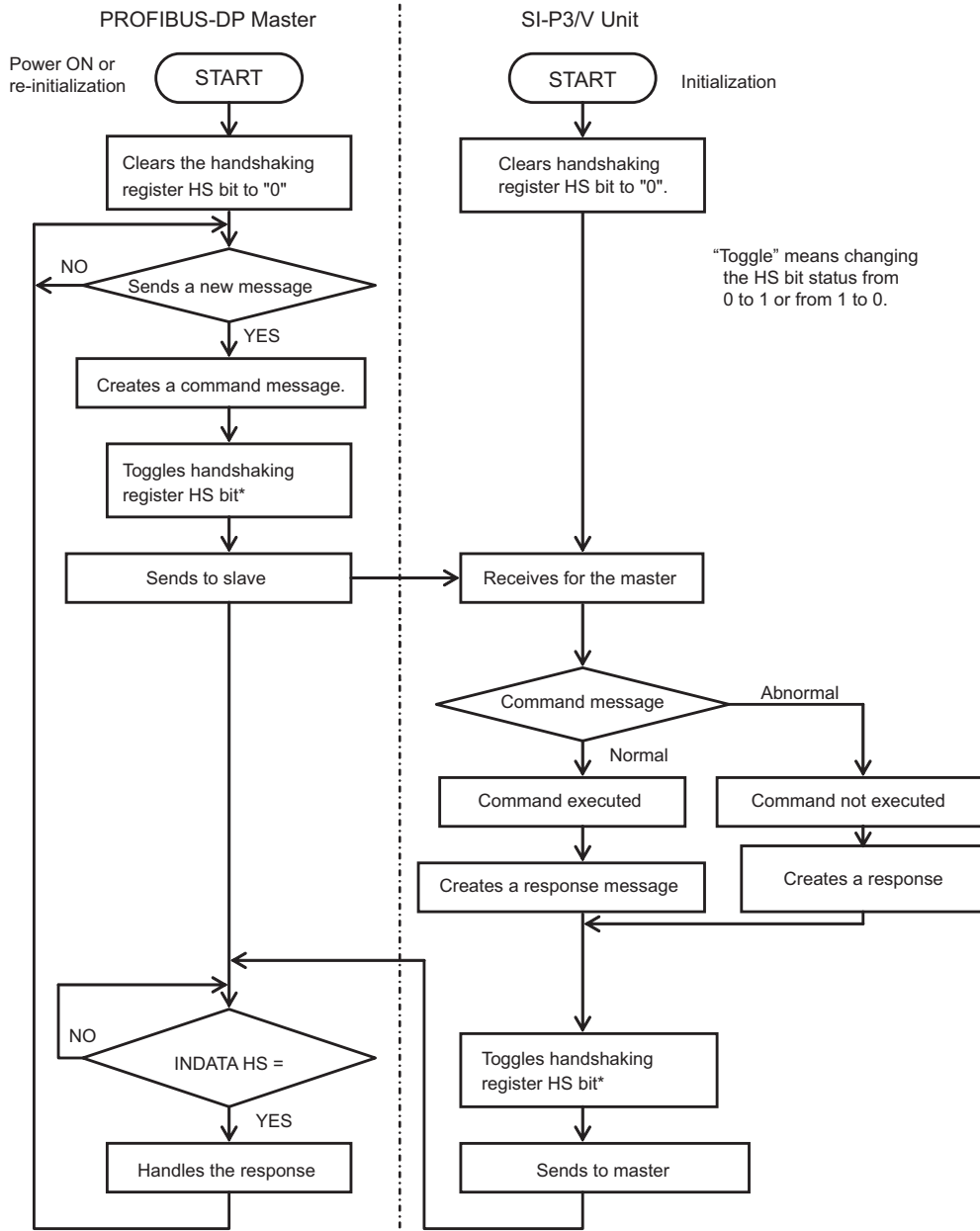

Figure 15 MEMOBUS/Modbus Message Flow Chart

## ◆ Command Data

Table 20 Command Data

Register	Command Name		Comments
	Bit		
0001H	Operation signal		
	0	Forward Run/Stop 1: Forward Run	
	1	Reverse Run/Stop 1: Reverse Run	
	2	External fault 1: Fault (EF0)	
	3	Fault reset 1: Fault reset	
	4	Multi-function digital input command 1	ComRef when set for Forward/Stop
	5	Multi-function digital input command 2	ComCtrl when set for Reverse/Stop
	6	Multi-function digital input command 3	
	7	Multi-function digital input command 4	
	8	Multi-function digital input command 5	
	9	Multi-function digital input command 6	
A	Multi-function digital input command 7		
0002H	Frequency reference		Determined by o1-03
0006H	PID setpoint		0.01% (signed)
0007H	Analog output 1		10 V / 4000 H
0009H	Multi-function digital output settings		
	0	Contact output (MA/MB-MC)	
	1	Photocoupler output 1 (P1)	
	2	Photocoupler output 2 (P2)	
000AH	Pulse output setting		1/1 Hz Setting range: 0 to 32000
000FH	Control Selection Setting		
	0	Reserved	
	1	PID Target Input	
	2 to F	Reserved	
0010H	Frequency reference		Units: min <sup>-1</sup> *
0011H	Frequency reference		0.01% (signed)

\* It is necessary to set the pole number (E2-04, E4-04, or E5-04) in the drive.

## ◆ Monitor Data

Table 21 Monitor Data

Register	Command Name		Comments
	Bit		
0020H	Drive status 1		
	0	During forward run	
	1	During reverse run	
	2	Drive ready	
	3	Fault	
	4	Data setting error	
	5	Contact output (MA/MB-MC)	
	6	Photocoupler output 1 (P1)	
	7	Photocoupler output 2 (P2)	
	E	ComRef status, NetRef status	
F	ComCtrl status, NetCtrl status		

\*1. It is necessary to set the pole number (E2-04, E4-04, or E5-04) in the drive.

\*2. See [Fault Contents on page 30](#) for information on fault contents.

\*3. See [Alarm Contents on page 32](#) for information on alarm contents.



## 8 Conventional Formats

Register	Command Name		Comments
	Bit		
0021H	Fault contents		
	0	Overcurrent (oC), Ground fault (GF)	
	1	Overvoltage (ov)	
	2	Drive overload (oL2)	
	3	Overheat 1 (oH1), Drive overheat warning (oH2)	
	4	Dynamic braking transistor (tr), Braking resistor overheat (rH)	
	6	PID feedback loss (FbL), Excessive PID feedback (FbH)	
	7	External fault (EF□), PROFIBUS-DP Option external fault (EF0)	
	8	PROFIBUS-DP Option fault (CPF or oFA)	
	9	Motor overload (oL1), Overtorque detection 1 (oL3), Overtorque detection 2 (oL4), Undertorque detection 1 (UL3), Undertorque detection 2 (UL4)	
	A	PG disconnect (for Simple V/f with PG) (PGo), (PGoH), Overspeed (for Simple V/f with PG) (oS), Excessive speed deviation (for Simple V/f with PG) (dEv)	
	B	Main circuit undervoltage (Uv) detecting	
	C	Undervoltage (Uv1), Control power supply undervoltage (Uv2), Soft charge circuit fault (Uv3)	
	D	Output phase loss (LF), Input phase loss (PF)	
E	MEMOBUS/Modbus communication error (CE), Option communication error (bUS)		
F	Operator connection fault (oPr)		
0022H	Data link status		
	0	Writing data or switching motors	
	1	Reserved	
	2		
	3	Upper or lower limit error	
	4	Data conformity error	
5	Writing to EEPROM		
0023H	Frequency reference (U1-01)		
0024H	Output frequency (U1-02)		
0025H	Output voltage reference (U1-06)		MEMOBUS/Modbus switches setting units according to H5-10: 0 = 0.1 V units, 1 = 1 V units
0026H	Output current (U1-03)		10/1 A
0027H	Output power (U1-08)		
0028H	Torque reference (U1-09)		
0029H	Fault contents 2		
	0	Reserved	
	1	Ground fault (GF)	
	2	Input phase loss (PF)	
	3	Output phase loss (LF)	
	4	Braking resistor overheat (rH)	
	6	Motor overheat 2 (PTC input) (oH4)	
	8	Reserved	
	9	Reserved	
002AH	Minor fault 1		
	2	Run command input error (EF)	
	3	Drive baseblock (bb)	
	4	Overtorque detection 1 (oL3)	
	5	Heatsink overheat (oH)	
	6	Overvoltage (ov)	
	7	Undervoltage (Uv)	
	8	Cooling fan error (FAN)	
	9	MEMOBUS/Modbus communication error (CE)	
	A	Option communication error (bUS)	
	B	Undertorque detection 1 (UL3), Undertorque detection 2 (UL4)	
	C	Motor Overheat (oH3)	
	D	PID feedback loss (FbL), Excessive PID feedback (FbH)	
F	Serial communication transmission error (CALL)		

\*1. It is necessary to set the pole number (E2-04, E4-04, or E5-04) in the drive.

\*2. See [Fault Contents on page 30](#) for information on fault contents.

\*3. See [Alarm Contents on page 32](#) for information on alarm contents.

Register	Command Name		Comments
	Bit		
002BH	Input terminal status (U1-10)		
	0	1: Control circuit terminal S1 closed	
	1	1: Control circuit terminal S2 closed	
	2	1: Control circuit terminal S3 closed	
	3	1: Control circuit terminal S4 closed	
	4	1: Control circuit terminal S5 closed	
	5	1: Control circuit terminal S6 closed	
002CH	Drive Status 2		
	0	During run	
	1	During zero speed	
	2	During Speed Agree	
	3	During user-set Speed Agree	
	4	Frequency detection 1	
	5	Frequency detection 2	
	6	Drive ready	
	7	During undervoltage	
	8	During baseblock	
	9	Frequency reference is not supplied by the PROFIBUS-DP Option	
	A	Run command is not supplied by the PROFIBUS-DP Option	
	B	Over/Under torque 1, 2	
	C	Frequency reference loss	
D	During fault restart		
E	During fault		
F	MEMOBUS/Modbus timeout		
002DH	Output terminal status (U1-11)		
	0	Contact output (MA/MB-MC)	
	1	Photocoupler output 1 (P1)	
	2	Photocoupler 2 (P2)	
002FH	Frequency reference bias (Up 2, Down 2 function)		1000/100%
0030H	Reserved		
0031H	DC bus voltage (U1-07)		
0032H	Torque reference (U1-09)		1/1%
0034H	Product code 1 [ASCII]		V', '0'
0035H	Product code 2 [ASCII]		A', '0'
0038H	PID feedback		1/0.1%
0039H	PID input		1/0.1%
003AH	PID output		1/0.1%
003DH	Communication error contents		
	0	CRC error	
	1	Data length error	
	3	Parity error	
	4	Overrun error	
	5	Framing error	
	6	Timed out	
003EH	Output frequency		Units: min <sup>-1</sup> *1
003FH	Output frequency		Units: 0.01%
0040H	Frequency reference (U1-01)		Determined by o1-03.
0041H	Output frequency (U1-02)		Determined by o1-03.
0042H	Output current (U1-03)		8192 / drive rated current
0043H	Control mode (U1-04)		
0044H	Motor speed (U1-05)		Determined by o1-03.
0045H	Output voltage reference (U1-06)		Units: 0.1 V
0046H	DC bus voltage (U1-07)		Units: 1 V
0047H	Output power (U1-08)		
0048H	Torque reference (U1-09)		Units: 0.1%

\*1. It is necessary to set the pole number (E2-04, E4-04, or E5-04) in the drive.

\*2. See [Fault Contents on page 30](#) for information on fault contents.

\*3. See [Alarm Contents on page 32](#) for information on alarm contents.

## 8 Conventional Formats

Register	Command Name		Comments
	Bit		
0049H	Input terminal status (U1-10)		
	0	Control terminal S1 closed	
	1	Control terminal S2 closed	
	2	Control terminal S3 closed	
	3	Control terminal S4 closed	
	4	Control terminal S5 closed	
	5	Control terminal S6 closed	
004AH	Output terminal status (U1-11)		
	0	Contact output (MA/MB-MC)	
	1	Photocoupler output 1 (P1)	
004BH	Drive status (U1-12)		
	0	During run	
	1	During zero speed	
	2	During reverse run	
	3	During fault reset signal input	
	4	During Speed Agree	
	5	Drive ready	
	6	Alarm	
	7	Fault	
	8	During operation error (oPE□□)	
	9	During momentary power loss	
	A	Motor 2 selected	
	B	Reserved	
	E	ComRef status, NetRef status	
F	ComCtrl status, NetCtrl status		
004CH	Accumulated operation time in 10 hour units (U4-01)		
004DH	Software number (U1-25)		
004EH	Terminal A1 input voltage (U1-13)	Units: 0.1%	
004FH	Terminal A2 input voltage (U1-14)	Units: 0.1%	
0051H	Motor secondary current (U6-01)		
0052H	Motor excitation current (U6-02)		
0053H	Output frequency after soft start (U1-16)		
0054H	ASR input (U6-03)		
0055H	ASR output (U6-04)		
0057H	PID feedback (U5-01)		
0059H	Output voltage reference (Vq) (U6-05)		
005AH	Output voltage reference (Vd) (U6-06)		
005BH	Software No. (ROM) (U1-26)		
005CH	kWH, lower 4 digits (U4-10)		
005DH	kWH, upper 5 digits (U4-11)		
005FH	q axis ACR output (U6-07)		
0060H	d axis ACR output (U6-08)		
0061H	oPE fault parameter (U1-18)		
0062H	Reserved		
0063H	PID input (U5-02)		
0064H	PID output (U5-03)		
0065H	PID setpoint (U5-04)		
0066H	MEMOBUS/Modbus error code (U1-19)		
0067H	Cooling fan operation time (U4-03)		
0068H	Reserved		
0070H	Reserved		
0071H	Reserved		
0072H	Reserved		
0073H	Reserved		
0075H	Number of Run commands (U4-02)		
0076H	Pulse train input terminal RP input value	1/1Hz	
007CH	Capacitor maintenance (U4-05)		
007DH	Input pulse monitor (U1-24)		
007EH	Cooling fan maintenance time period (U4-04)		
007FH	Alarm code		

\*1. It is necessary to set the pole number (E2-04, E4-04, or E5-04) in the drive.

\*2. See [Fault Contents on page 30](#) for information on fault contents.

\*3. See [Alarm Contents on page 32](#) for information on alarm contents.

Register	Command Name		Comments
	Bit		
0080H		Current fault (U2-01)	
0081H		Previous fault (U2-02)	
0082H		Frequency reference at previous fault (U2-03)	
0083H		Output reference at previous fault (U2-04)	
0084H		Output current at previous fault (U2-05)	
0085H		Motor speed at previous fault (U2-06)	
0086H		Output voltage at previous fault (U2-07)	
0087H		DC bus voltage at previous fault (U2-08)	
0088H		Output power at previous fault (U2-09)	
0089H		Torque reference at previous fault (U2-10)	
008AH		Input terminal status at previous fault (U2-11)	
008BH		Output terminal status at previous fault (U2-12)	
008CH		Drive operation status at previous fault (U2-13)	
008DH		Cumulative operation time at previous fault (U2-14)	
008EH		Reserved	
0090H		Most recent fault (U3-01)	
0091H		2nd most recent fault (U3-02)	
0092H		3rd most recent fault (U3-03)	
0093H		4th most recent fault (U3-04)	
0094H		Cumulative operation time at most recent fault (U3-11)	
0095H		Cumulative operation time at 2nd most recent fault (U3-12)	
0096H		Cumulative operation time at 3rd most recent fault (U3-13)	
0097H		Cumulative operation time at 4th most recent fault (U3-14)	
0098H		Cumulative operation time	Shows "X" digit of the operation time, which is displayed as "XY" For the "Y" digit, see 1099H
0099H		Cumulative operation time	Shows "Y" digit of the operation time, which is displayed as "XY" For the "X" digit, see 1098H
009AH		Cooling fan operation time, upper digits	Shows "X" digit of the operation time, which is displayed as "XY" For the "Y" digit, see 1099H
009BH		Cooling fan operation time, lower digits	Shows "Y" digit of the operation time, which is displayed as "XY" For the "X" digit, see 1098H
00ABH		Drive rated current	The unit is 0.01 A for drives set up to 11 kW in Heavy Duty or Normal Duty and 0.1 A for drives set up for 15 kW and above.
00ACH		Motor speed (U1-05)	Units: min <sup>-1</sup> *1
00ADH		Motor speed (U1-05)	Units: 0.01%
00AEH		Iac monitor with filter	8192/100%
00B0H		Option A code	The option code for the communication card is the ASCII code for the first and third digits of the product model number. If the model number is SIP3, then the first and third digits are "S" and "P", for an ASCII code of 5343H.
00B2H		Reserved	
00B3H		Reserved	
00B5H		Output frequency after soft starter (U1-16)	Units: min <sup>-1</sup> *1
00B6H		Output frequency after soft starter (U1-16)	Units: 0.01%
00B7H		Frequency reference monitor	Units: min <sup>-1</sup> *1
00B8H		Frequency reference monitor	Units: 0.01%
00B9H		Reserved	
00BAH		Reserved	
00BFH		Operation error number (oPE□□)	

\*1. It is necessary to set the pole number (E2-04, E4-04, or E5-04) in the drive.

\*2. See [Fault Contents on page 30](#) for information on fault contents.

\*3. See [Alarm Contents on page 32](#) for information on alarm contents.

## 8 Conventional Formats

Register	Command Name		Comments
	Bit		
00C0H	Fault contents 1 *2		
	1	Undervoltage (Uv1)	
	2	Control power supply undervoltage (Uv2)	
	3	Soft charge circuit fault (Uv3)	
	4	Reserved	
	5	Ground fault (GF)	
	6	Overcurrent (oC)	
	7	Overvoltage (ov)	
	8	Heatsink overheat (oH)	
	9	Heatsink overheat (oH1)	
	A	Motor overload (oL1)	
	B	Drive overload (oL2)	
	C	Overtorque detection 1 (oL3)	
	D	Overtorque detection 2 (oL4)	
	E	Dynamic braking transistor (rr)	
F	Braking resistor overheat (rH)		
00C1H	Fault contents 2 *2		
	0	External fault at input terminal S3 (EF3)	
	1	External fault at input terminal S4 (EF4)	
	2	External fault at input terminal S5 (EF5)	
	3	External fault at input terminal S6 (EF6)	
	4	External fault at input terminal S7 (EF7)	
	7	Overspeed (oS)	Possible only when using Simple V/f with PG
	8	Excessive speed deviation (dEv)	Possible only when using Simple V/f with PG
	9	PG disconnect (PGo)	Possible only when using Simple V/f with PG
	A	Input phase loss (PF)	
	B	Output phase loss (LF)	
	C	Motor overheat (PTC input) (oH3)	
	D	Digital operator connection fault (oPr)	
	E	EEPROM write error (Err)	
	F	Motor overheat fault (PTC input) (oH4)	
00C2H	Fault contents 3 *2		
	0	MEMOBUS/Modbus communication error (CE)	
	1	Option communication error (bUS)	
	4	Control fault (CF)	
	5	Reserved	
	6	PROFIBUS-DP Option external fault (EF0)	
	7	PID feedback loss (FbL)	
	8	Undertorque detection 1 (UL3)	
	9	Undertorque detection 2 (UL4)	
	A	High Slip Braking overload (oL7)	
	F	Hardware fault (includes oFx)	
00C3H	Fault contents 4 *2		
	0	Reserved	
	1		
	2		
	3		
	4		
	5	Output current imbalance (LF2)	
	6	Pullout detection (Sto)	
	7	PG disconnect (PGo)	Possible only when using Simple V/f with PG
	8	Reserved	
	A	Too many speed search restarts (SEr)	
	B	Reserved	
	C		
	D		
E			
F			

\*1. It is necessary to set the pole number (E2-04, E4-04, or E5-04) in the drive.

\*2. See [Fault Contents on page 30](#) for information on fault contents.

\*3. See [Alarm Contents on page 32](#) for information on alarm contents.

Register	Command Name		Comments
	Bit		
00C4H	Fault contents 5 *2		
	0	Excessive PID feedback (FbH)	
	1	External fault 1, input terminal S1 (EF1)	
	2	External fault 2, input terminal S2 (EF2)	
	3	Mechanical weakening detection 1 (oL5)	
	4	Mechanical weakening detection 2 (UL5)	
	5	Current offset fault (CoF)	
	6	Reserved	
	7	Reserved	
00C8H	Alarm contents 1 *3		
	0	Undervoltage (Uv)	
	1	Overvoltage (ov)	
	2	Heatsink overheat (oH)	
	3	Drive overheat (oH2)	
	4	Overtorque 1 (oL3)	
	5	Overtorque 2 (oL4)	
	6	Run commands input error (EF)	
	7	Drive baseblock (bb)	
	8	External fault 3, input terminal S3 (EF3)	
	9	External fault 4, input terminal S4 (EF4)	
	A	External fault 5, input terminal S5 (EF5)	
	B	External fault 6, input terminal S6 (EF6)	
	C	External fault 7, input terminal S7 (EF7)	
	E	Cooling fan error (FAN)	
F	Overspeed (oS)	Possible only when using Simple V/f with PG	
00C9H	Alarm contents 2 *3		
	0	Excessive speed deviation (dEv)	Possible only when using Simple V/f with PG
	1	PG disconnect (PGo)	Possible only when using Simple V/f with PG
	2	Digital operator connection fault (oPr)	
	3	MEMOBUS/Modbus communication error (CE)	
	4	Option communication error (bUS)	
	5	Serial communication transmission error (CALL)	
	6	Motor overload (oL1)	
	7	Drive overload (oL2)	
	8	Reserved	
	9	PROFIBUS-DP Option external fault (EF0)	
	A	During run 2, Motor switch command input (rUn)	
	C	Serial communication transmission error (CALL)	
	D	Undertorque detection 1 (UL3)	
	E	Undertorque detection 2 (UL4)	
F	MEMOBUS/Modbus test mode fault (SE)		
00CAH	Alarm contents 3 *3		
	1	Motor overheat 1 (PTC Input) (oH3)	
	6	PID feedback loss (FbL)	
	7	Excessive PID feedback (FbH)	
	9	Drive disabled (dnE)	
	A	PG disconnect (PGo)	Possible only when using Simple V/f with PG
	B	Reserved	
	C	Reserved	
	D	Reserved	
E	Reserved		
F	Reserved		

\*1. It is necessary to set the pole number (E2-04, E4-04, or E5-04) in the drive.

\*2. See [Fault Contents on page 30](#) for information on fault contents.

\*3. See [Alarm Contents on page 32](#) for information on alarm contents.

## 8 Conventional Formats

Register	Command Name		Comments
	Bit		
00CBH	Alarm contents 4 *3		
	0	Reserved	
	1	Reserved	
	2	Reserved	
	3	Current alarm (HCA)	
	7	Reserved	
	8	External fault 1 (input terminal S1) (EF1)	
	9	External fault 2 (input terminal S2) (EF2)	
	A	Hardwire baseblock signal input (HbbF)	
	B	Hardwire baseblock signal input (Hbb)	
	C	Mechanical weakening detection 1 (oL5)	
	D	Mechanical weakening detection 2 (UL5)	
E	Reserved		
F	Reserved		
00CCH	Alarm contents 5 *3		
	8	DriveWorksEZ alarm (dWAL)	
	2	A/D Conversion Error (CPF02)	
	3	PWM Data Fault (CPF03)	
	5	Reserved	
	6	Drive specification mismatch during Terminal Board or Control Board replacement (CPF06)	
	7	Terminal Board Communications Fault (CPF07)	
	8	EEPROM Serial Communications Fault (CPF08)	
	B	RAM Fault (CPF11)	
	C	FLASH Memory Fault (CPF12)	
	D	Watchdog Circuit Exception (CPF13)	
	E	Control Circuit Fault (CPF14)	
00D1H	CPF contents 2 *2		
	0	Clock fault (CPF16)	
	1	Timing fault (CPF17)	
	2	Control circuit fault (CPF18)	
	3	Control circuit fault (CPF19)	
	4	Hardware fault at power up (CPF20)	
	5	Hardware fault at communication start up (CPF21)	
	6	A/D conversion fault (CPF22)	
	7	PWM feedback fault (CPF23)	
	8	Drive capacity signal fault (CPF24)	
9	Reserved		
00D8H	oFAx contents *2		
	0	Option compatibility error (oFA00)	
	1	Option not properly connected (oFA01)	
	3	Option self-diagnostics error (oFA03)	
	4	Option Flash write mode error (oFA04)	
00D9H	Reserved		
00DBH	Reserved		
00F0H	Reserved		
00F2H	Reserved		
00FBH	Output current (U1-03)	The unit is 0.01 A for drives set up to 11 kW in Heavy Duty or Normal Duty and 0.1 A for drives set up for 15 kW and above.	
00FCH	Reserved		
00FDH	Reserved		

\*1. It is necessary to set the pole number (E2-04, E4-04, or E5-04) in the drive.

\*2. See [Fault Contents on page 30](#) for information on fault contents.

\*3. See [Alarm Contents on page 32](#) for information on alarm contents.

### ◆ Fault Contents

Table 22 Fault Contents

Fault Code (U2, U3)	Fault Name
	Fault contents 1
0001H	Undervoltage (Uv1)
0002H	Control power supply undervoltage (Uv2)
0004H	Soft charge circuit fault (Uv3)
0005H	Reserved
0006H	Ground fault (GF)

Fault Code (U2, U3)	Fault Name
0007H	Overcurrent (oC)
0008H	Overvoltage (ov)
0009H	Heatsink overheat (oH)
000AH	Heatsink overheat (oH1)
000BH	Motor overload (oL1)
000CH	Drive overload (oL2)
000DH	Overtorque detection 1 (oL3)
000EH	Overtorque detection 2 (oL4)
000FH	Dynamic braking transistor (rr)
0010H	Braking resistor overheat (rH)
	Fault contents 2
0011H	External fault at input terminal S3 (EF3)
0012H	External fault at input terminal S4 (EF4)
0013H	External fault at input terminal S5 (EF5)
0014H	External fault at input terminal S6 (EF6)
0015H	External fault at input terminal S7 (EF7)
0018H	Overspeed (oS) <b>Note:</b> Possible only when using Simple V/f with PG
0019H	Excessive speed deviation (dEv) <b>Note:</b> Possible only when using Simple V/f with PG
001AH	PG disconnect (PGo) <b>Note:</b> Possible only when using Simple V/f with PG
001BH	Input phase loss (PF)
001CH	Output phase loss (LF)
001DH	Motor overheat (PTC input) (oH3)
001EH	Digital operator connection fault (oPr)
001FH	EEPROM write error (Err)
0020H	Motor overheat fault (PTC input) (oH4)
	Fault contents 3
0021H	MEMOBUS/Modbus communication error (CE)
0022H	Option communication error (bUS)
0025H	Control fault (CF)
–	Reserved
0027H	PROFIBUS-DP Option external fault (EF0)
0028H	PID feedback loss (FbL)
0029H	Undertorque detection 1 (UL3)
002AH	Undertorque detection 2 (UL4)
002BH	High Slip Braking overload (oL7)
0030H	Hardware fault (including oFx)
	Fault contents 4
–	Reserved
0036H	Output current imbalance (LF2)
0037H	Pullout detection (Sto)
0038H	PG disconnect (PGo) <b>Note:</b> Possible only when using Simple V/f with PG
–	Reserved
003BH	Too many speed search restarts (SEr)
–	Reserved
–	Reserved
–	Reserved
–	Reserved
–	Reserved
	Fault contents 5
0041H	Excessive PID feedback (FbH)
0042H	External fault 1, input terminal S1 (EF1)
0043H	External fault 2, input terminal S2 (EF2)
0044H	Mechanical weakening detection 1 (oL5)
0045H	Mechanical weakening detection 2 (UL5)
0046H	Current offset fault (CoF)
–	Reserved
–	Reserved
0049H	DriveWorksEZ fault (dWFL)
	CPF contents 1
0083H	A/D conversion error (CPF02)
0084H	PWM data fault (CPF03)
0086H	Reserved
0087H	Drive specification mismatch during Terminal Board or Control Board replacement (CPF06)
0088H	Terminal board communication fault (CPF07)
0089H	EEPROM serial communication fault (CPF08)
008CH	RAM fault (CPF11)



## 8 Conventional Formats

Fault Code (U2, U3)	Fault Name
008DH	Flash memory circuit exception (CPF12)
008EH	Watchdog circuit exception (CPF13)
008FH	Control circuit fault (CPF14)
	CPF Contents 2
0091H	Clock fault (CPF16)
0092H	Timing fault (CPF17)
0093H	Control circuit fault (CPF18)
0094H	Control circuit fault (CPF19)
0095H	Hardware fault at power up (CPF20)
0096H	Hardware fault at communication start up (CPF21)
0097H	A/D conversion fault (CPF22)
0098H	PWM feedback fault (CPF23)
0099H	Drive capacity signal fault (CPF24)
009AH	Reserved
	oFAx contents
0101H	Option compatibility error (oFA00)
0102H	Option not properly connected (oFA01)
0104H	Option self-diagnostics error (oFA03)
0105H	Option Flash write mode error (oFA04)

### ◆ Alarm Contents

Table 23 Alarm Contents

Alarm Code (007FH)	Alarm Name
	Alarm contents 1
0001H	Undervoltage (Uv)
0002H	Overvoltage (ov)
0003H	Heatsink overheat (oH)
0004H	Drive overheat (oH2)
0005H	Overtorque 1 (oL3)
0006H	Overtorque 2 (oL4)
0007H	Run commands input error (EF)
0008H	Drive baseblock (bb)
0009H	External fault 3, input terminal S3 (EF3)
000AH	External fault 4, input terminal S4 (EF4)
000BH	External fault 5, input terminal S5 (EF5)
000CH	External fault 6, input terminal S6 (EF6)
000DH	External fault 7, input terminal S7 (EF7)
000FH	Cooling fan error (FAN)
0010H	Overspeed (oS) <b>Note:</b> Possible only when using Simple V/f with PG
	Alarm Contents 2
0011H	Excessive speed deviation (dEv) <b>Note:</b> Possible only when using Simple V/f with PG
0012H	PG disconnect (PGo) <b>Note:</b> Possible only when using Simple V/f with PG
0013H	Digital operator connection fault (oPr)
0014H	MEMOBUS/Modbus communication error (CE)
0015H	Option communication error (bUS)
0016H	Serial communication transmission error (CALL)
0017H	Motor overload (oL1)
0018H	Drive overload (oL2)
-	Reserved
001AH	PROFIBUS-DP Option external fault (EF0)
001BH	During run 2, Motor switch command input (rUn)
001DH	Serial communication transmission error (CALL)
001EH	Undertorque detection 1 (UL3)
001FH	Undertorque detection 2 (UL4)
0020H	MEMOBUS/Modbus test mode fault (SE)
	Alarm contents 3
0022H	Motor overheat (oH3)
0027H	PID feedback loss (FbL)
0028H	Excessive PID feedback (FbH)
002AH	Drive disabled (dnE)
002BH	PG Disconnect (PGo) <b>Note:</b> Possible only when using Simple V/f with PG
-	Reserved
-	Reserved
-	Reserved
-	Reserved

Alarm Code (007FH)	Alarm Name
–	Reserved
	Alarm contents 4
–	Reserved
–	Reserved
–	Reserved
0034H	Current alarm (HCA)
–	Reserved
0039H	External fault (input terminal S1) (EF1)
003AH	External fault (input terminal S2) (EF2)
003BH	Hardwire baseblock signal input (HbbF)
003CH	Hardwire baseblock signal input (Hbb)
003DH	Mechanical weakening detection 1 (oL5)
003EH	Mechanical weakening detection 2 (UL5)
–	Reserved
–	Reserved
	Alarm contents 5
0049H	DriveWorksEZ alarm (dWAL)



■ IND

Bit	PPO Write	PPO Read
0	Reserved	Reserved
1		
2		
3		
4		
5		
6		
7		
8	Sub-Index for parameter number	Sub-Index for parameter number
9		
10		
11		
12		
13		
14		
15		

■ PWE

Bit	PPO Write	PPO Read
	Setting Data	Error code when Response ID is 7 0: Incorrect PNU number 1: Write mode error 2: Lower or upper limit violated 17: Write mode error during Uv condition or Write mode error during parameter processing

■ STW/ZSW

Bit	PPO Write	PPO Read
0	OFF1: ignored	Ready to switch on: always 1
1	OFF2: ignored	Ready: always 1
2	OFF3: ignored	0: Not ready 1: Drive ready
3	Enable to RUN 0: Baseblock + Stop 1: Not Baseblock	0: No fault condition 1: Fault condition
4	0: STOP 1: RUN	Always 1
5	Ramp function generation enable: ignored	Always 1
6	Enable ramp function generator set-point: ignored	Switch-on inhibit: always 0
7	1: Fault Reset	0: No alarm condition 1: Alarm condition
8	0: Stop 1: JOG RUN forward (Fmax/10 speed)	0: No speed agree 1: Speed agree condition
9	0: Stop 1: JOG RUN reverse (Fmax/10 speed)	0: Local control 1: Control from PROFIBUS
10	0: Local control 1: Control from PROFIBUS	Always 0
11	Ignored	
12		
13		
14		
15		

■ HSW/HIW

Bit	PPO Write	PPO Read
	Setting Frequency (±10000/100%)	Output Frequency or Motor speed (with PG) (±10000/100%)

■ Task ID

ID	Description
0	No action
1	Request parameter value
2	Change parameter value (word)
3	Change parameter value (double word)
6	Request parameter value from array
7	Change parameter value in array (word)
8	Change parameter value in array (double word)

## 9 Parameter Process Data Object Formats

ID	Description
9	Request number of array elements

### ■ Response ID

ID	Description
0	No action
1	Transfer parameter value (word)
2	Transfer parameter value (double word)
4	Transfer parameter value (array word)
5	Transfer parameter value (array double word)
6	Transfer number of array element
7	Task cannot be executed (with error number)

### ◆ SI-P3/V Device Data

Parameter	Setting Value	Note
GSD_Revision	3	GSD file revision 3.0.
Vendor_Name	"YASKAWA ELECTRIC"	
Model_Name	"PROFIBUS-DP INTERFACE CARD SI-P3"	
Ident_Number	0x0ACF	
FMS_supp	0	PROFIBUS-FMS not supported
Protocol_Ident	0	PROFIBUS-DP supported
Station_Type	0	DP-Slave.
Slave_Family	3	
Revision	"V1.0"	Device revision 1.0
Hardware_Release	"V1.0"	Hardware revision 1.0
Software_Release	"V1.0"	Software revision 1.0
Implementation_type	"DPC31"	DP protocol
Redundancy	0	Redundancy NOT supported
Repeater_Ctrl_Sig	2	Supported, TTL level
24V_Pins	0	No external 24 Volt input
Set_Slave_Add_supp = 1	1	Station address is set remotely
Auto_Baud_supp	1	Automatic baud rate select
9.6_supp	1	9600 Baud
19.2_supp	1	19.2 kBaud
45.45_supp	1	45.45 kBaud
93.75_supp	1	93.75 kBaud
187.5_supp	1	187.5 kBaud
500_supp	1	500 kBaud
1.5M_supp	1	1.5 MBaud
3M_supp	1	3 MBaud
6M_supp	1	6 MBaud
12M_supp	1	12 MBaud
MaxTsdr_9.6	60	60 Tbit = 6.25 msec
MaxTsdr_19.2	60	60 Tbit = 3.125 msec
MaxTsdr_45.45	60	60 Tbit = 1.32 msec
MaxTsdr_93.75	60	60 Tbit = 640 usec
MaxTsdr_187.5	60	60 Tbit = 320 usec
MaxTsdr_500	100	100 Tbit = 200 usec
MaxTsdr_1.5M	150	150 Tbit = 100 usec
MaxTsdr_3M	250	250 Tbit = 83 usec
MaxTsdr_6M	450	450 Tbit = 75 usec
MaxTsdr_12M	800	800 Tbit = 67 usec
Min_Slave_Intervall	5	Minimum slave interval=0.5 ms
Freeze_Mode_supp	1	Freeze mode not supported
Sync_Mode_supp	1	Sync mode not supported
Fail_Safe	1	Fail safe supported
DPV1_Slave	1	
DPV1_Data_Types	1	
C1_Read_Write_supp	0	
C2_Read_Write_supp	1	
C2_Max_Data_Len	240	
C2_Response_Timeout	100	
C2_Read_Write_required	0	
C2_Max_Count_Channels	1	
Max_Initiate_PDU_Length	52	

Parameter	Setting Value	Note
Modular_Station	1	Modular station.
Max_Module	1	Maximum # of modules: 1
Max_Input_Len	32	Maximum # of input bytes
Max_Output_Len	32	Maximum # of output bytes
Max_Data_Len	64	Maximum # of data bytes
Max_User_Prm_Data_Len	4	
Ext_User_Prm_Data_Const(0)	0x40,0x01,0x00,0x01	
Ext_User_Prm_Data_Ref(0)	1	
Ext_User_Prm_Data_Ref(0)	2	
Max_Diag_Data_Len	11	Maximum diagnostic length
Unit_Diag_Bit(0024)	"Undervoltage Condition"	
Unit_Diag_Bit(0025)	"Inverter Communications Error"	
Unit_Diag_Bit(0026)	"PNU915: Illegal PNU configured"	
Unit_Diag_Bit(0027)	"PNU916: Illegal PNU configured"	

Module = "Basic data" 0x72 1 EndModule
Module = "Extended Data 1" 0x5F, 0x6F 2 EndModule
Module = "Extended Data 2" 0x55, 0x65 3 EndModule
Module = "PPO Type 1" 0xF3, 0xF1 4 EndModule
Module = "PPO Type 2" 0xF3, 0xF5 5 EndModule
Module = "PPO Type 3" 0xF1 6 EndModule
Module = "PPO Type 4" 0xF5 7 EndModule
Module = "PPO Type 5" 0xF3, 0xF9 8 EndModule
Module = "PPO Type 1 (No Cons.)" 0x73, 0x71 9 EndModule
Module = "PPO Type 2 (No Cons.)" 0x73, 0x75 10 EndModule
Module = "PPO Type 3 (No Cons.)" 0x71 11 EndModule
Module = "PPO Type 4 (No Cons.)" 0x75 12 EndModule
Module = "PPO Type 5 (No Cons.)" 0x73, 0x79 13 EndModule

◆ Supported PNU

Supported PNU No.	Data type	Description
900	Octet String 12	Type 1 PPO-Write
901	Octet String 20	Type 2 PPO-Write
902	Octet String 4	Type 3 PPO-Write (DP-V1only)
903	Octet String 12	Type 4 PPO-Write (DP-V1only)
904	Unsigned 16	Current PPO-Write
905	Octet String 28	Type 5 PPO-Write
907	Octet String 12	Type 1 PPO-Read

## 9 Parameter Process Data Object Formats

Supported PNU No.	Data type	Description
908	Octet String 20	Type 2 PPO-Read
909	Octet String 4	Type 3 PPO-Read (DP-V1 only)
910	Octet String 12	Type 4 PPO-Read (DP-V1 only)
911	Unsigned 16	Current PPO-Read
912	Octet String 28	Type 5 PPO-Read
915	Array[10] Unsigned 16	Assign MEMOBUS/Modbus Write Command to PZD in PPO-Write
916	Array[10] Unsigned 16	Assign MEMOBUS/Modbus response to PZD in PPO-Read
918	Unsigned 16	Node address
947	Array[10] Unsigned 16	Fault number
948	Array[10] Unsigned 16	Fault time (Elapsed time between fault occurrence)
963	Unsigned 16	Current baud rate
964		Device identification (see Table)
965	Octet String 2	Profile code: 0x0302
967	V2	Read or Write Control word
968	V2	Read Status word
971	Unsigned 16	Start Store in non-volatile memory (Enter code with EEPROM)

### ■ Example: To read the Drive Command (STW) using PNU900

#### Command setting

Data type	Settings	Description
PKE	6384H	6 request parameter value from Array 384H=900 dec (PNU 900)
IND	5	5th Word data of PPO type 1
PWE	0	N/A
STW	–	up to Master command
HSW	–	up to Master command

#### Response

Data type	Settings	Description
PKE	4384H	4 Transfer parameter value (array word) 384H=900 dec (PNU 900)
IND	5	5th Word data of PPO type 1
PWE	(STW)	STW data
ZSW	–	up to drive status
HIW	–	up to drive status

### ■ Example: To read the Drive Status (ZSW) using PNU907

#### Command setting

Data type	Settings	Description
PKE	638BH	6 request parameter value from Array 38BH=907 dec (PNU 907)
IND	5	5th Word data of PPO type 1
PWE	0	N/A
STW	–	up to Master command
HSW	–	up to Master command

#### Response

Data type	Settings	Description
PKE	438BH	4 Transfer parameter value (array word) 38BH=907 dec (PNU 907)
IND	5	5th Word data of PPO type 1
PWE	(ZSW)	ZSW data
ZSW	–	up to drive status
HIW	–	up to drive status

### ■ Example: To read the data Type 1 PPO-Write 1st word

#### Command setting

Data type	Settings	Description
PKE	6384H	6 request parameter value from Array 384H=900 dec (PNU 900)
IND	1	First Word data of PPO type 1
PWE	0	N/A
STW	–	up to Master command
HSW	–	up to Master command

## Response

Data type	Settings	Description
PKE	4384H	4 Transfer parameter value (array word)
		384H=900 dec (PNU 900)
IND	1	First Word data of PPO type 1
PWE	6384H	PPO-Write 1st Word data
ZSW	-	up to drive status
HIW	-	up to drive status

■ Example: To read current PPO-Write

## Command setting

Data type	Settings	Description
PKE	1388H	1 request parameter value
		388H=904 dec (PNU 904)
IND	0	Not array type
PWE	0	N/A
STW	-	up to Master command
HSW	-	up to Master command

## Response

Data type	Settings	Description
PKE	1388H	1 Transfer parameter value
		388H=904 dec (PNU 904)
IND	0	Not array type
PWE	1	1: Type 1 PPO-Write 2: Type 2 PPO-Write 3: Type 3 PPO-Write 4: Type 4 PPO-Write 5: Type 5 PPO-Write
ZSW	-	up to drive status
HIW	-	up to drive status

■ How to use PNU 915 (Assignment, PZD in PPO-Write)

PZD #	PNU	INDX	Assigned PNU	Description
PZD1	915	1	P0.1	Operation command
PZD2	915	2	P0.2	Frequency Reference
PZD3	915	3	P0.6	PID set point
PZD4	915	4	P0.7	Analog Output
PZD5	915	5	P0.9	Digital Output
PZD6	915	6	P0.15	PID set point enable
PZD7	915	7		
PZD8	915	8		
PZD9	915	9		
PZD10	915	10		

■ How to use PNU 916 (Assignment, PZD in PPO-Read)

PZD #	PNU	INDX	Assigned PNU	Description
PZD1	916	1	P0.32	Drive Status
PZD2	916	2	P0.2	Frequency Reference
PZD3	916	3	P0.36	Output Frequency
PZD4	916	4	P0.37	Output Current
PZD5	916	5	P0.68	Motor Speed
PZD6	916	6	P0.69	Output Voltage
PZD7	916	7	P0.70	Bus Voltage
PZD8	916	8	P0.72	Torque Monitor
PZD9	916	9	P0.71	Output Power
PZD10	916	10	P0.73	Input terminal status

■ PNU963

Value	Baud rate (kbit/s)
0	9.6
1	19.2
2	93.75
3	187.5
4	500



## 9 Parameter Process Data Object Formats

Value	Baud rate (kbit/s)
6	1500
7	3000
8	6000
9	12000

### ■ PNU964

Sub-Index	Description	Settings
0	Manufacturer Coding, refer to [10]	273 dec
1	Device type	1
2	Software version	0
3	Firmware Data (year)	2007 dec
4	Firmware Data (day/month)	0220 dec
5	DO	1

### ◆ PNU Number for V1000 Parameters

DPV0 PNU Number (Dec)	Description	INDEX (Dec)
11	A1 Function Group	00-99
12	A2 Function Group	00-99
21	B1 Function Group	00-99
22	B2 Function Group	00-99
23	B3 Function Group	00-99
24	B4 Function Group	00-99
25	B5 Function Group	00-99
26	B6 Function Group	00-99
28	B8 Function Group	00-99
31	C1 Function Group	00-99
32	C2 Function Group	00-99
33	C3 Function Group	00-99
34	C4 Function Group	00-99
35	C5 Function Group	00-99
36	C6 Function Group	00-99
41	D1 Function Group	00-99
42	D2 Function Group	00-99
43	D3 Function Group	00-99
44	D4 Function Group	00-99
47	D7 Function Group	00-99
51	E1 Function Group	00-99
52	E2 Function Group	00-99
53	E3 Function Group	00-99
54	E4 Function Group	00-99
55	E5 Function Group	00-99
61	F1 Function Group	00-99
66	F6 Function Group	00-99
67	F7 Function Group	00-99
81	H1 Function Group	00-99
82	H2 Function Group	00-99
83	H3 Function Group	00-99
84	H4 Function Group	00-99
85	H5 Function Group	00-99
86	H6 Function Group	00-99
121	L1 Function Group	00-99
122	L2 Function Group	00-99
123	L3 Function Group	00-99
124	L4 Function Group	00-99
125	L5 Function Group	00-99
126	L6 Function Group	00-99
127	L7 Function Group	00-99
128	L8 Function Group	00-99
141	N1 Function Group	00-99
142	N2 Function Group	00-99
143	N3 Function Group	00-99
146	N6 Function Group	00-99
148	N8 Function Group	00-99

DPV0 PNU Number (Dec)	Description	INDEX (Dec)
151	O1 Function Group	00-99
152	O2 Function Group	00-99
153	O3 Function Group	00-99
154	O4 Function Group	00-99
171	Q1 Function Group	00-99
181	R1 Function Group	00-99
211	U1 Function Group	00-99
212	U2 Function Group	00-99
213	U3 Function Group	00-99
214	U4 Function Group	00-99
215	U5 Function Group	00-99
216	U6 Function Group	00-99
218	U8 Function Group	00-99
201	T1 Function Group	00-99
202	T2 Function Group	00-99
300	RAM Enter Command	0
301	ROM Enter Command	0

■ PNU Numbering for MEMOBUS/Modbus registers

DPV0 PNU Number	Description	INDEX
Command		
0	0001H MEMOBUS/Modbus #	1
0	0002H MEMOBUS/Modbus #	2
0	0007H MEMOBUS/Modbus #	7
0	0009H MEMOBUS/Modbus #	9
0	000AH MEMOBUS/Modbus #	10
0	000FH MEMOBUS/Modbus #	15
0	0010H MEMOBUS/Modbus #	16
0	0011H MEMOBUS/Modbus #	17
Monitor		
0	0020H MEMOBUS/Modbus #	32
0	0021H MEMOBUS/Modbus #	33
0	0022H MEMOBUS/Modbus #	34
0	0023H MEMOBUS/Modbus #	35
0	0024H MEMOBUS/Modbus #	36
0	0025H MEMOBUS/Modbus #	37
0	0026H MEMOBUS/Modbus #	38
0	0027H MEMOBUS/Modbus #	39
0	0028H MEMOBUS/Modbus #	40
0	0029H MEMOBUS/Modbus #	41
0	002AH MEMOBUS/Modbus #	42
0	002BH MEMOBUS/Modbus #	43
0	002CH MEMOBUS/Modbus #	44
0	002DH MEMOBUS/Modbus #	45
0	002EH MEMOBUS/Modbus #	46
0	002FH MEMOBUS/Modbus #	47
0	0030H MEMOBUS/Modbus #	48
0	0031H MEMOBUS/Modbus #	49
0	0032H MEMOBUS/Modbus #	50
0	0033H MEMOBUS/Modbus #	51
0	0034H MEMOBUS/Modbus #	52
0	...	...
0	00FFH MEMOBUS/Modbus #	255

**Note:** When PNU is set to 0 and INDEX is set to MEMOBUS/Modbus register number, V1000 parameter values can be read and written instead of using PNU number.  
**Note:** MEMOBUS/Modbus register C1-01 is 200Hex  
 When PNU is 0 and INDEX is 200H(512 dec), C1-01 setting value can be read and written instead of using PNU 31(dec) and INDEX 01.

■ Enter Command (Write Only)

To write in a parameter to the drive from the PROFIBUS-DP master, be sure to send an Enter command. The written set value becomes valid when the drive receives the Enter command. There are two types of Enter commands as described below.

Register No.	Contents	Set Value
0900H	Saves parameter data to EEPROM	0000H
0910H	Updates parameter data to RAM without saving to EEPROM	0000H

## 9 Parameter Process Data Object Formats

### Enter command that writes in a parameter to the non-volatile memory

This command is executed by writing 0 to MEMOBUS/Modbus register number 0900H. When this command is executed, the changed set value is written in to the non-volatile memory and becomes valid. The value is stored in the drive even after the power supply is turned off. The data can only be written in to the non-volatile memory of the drive up to 100,000 times.

### Enter command that does not write in a parameter to the non-volatile memory

This command is executed by writing 0 to MEMOBUS/Modbus register number 0910H. When this command is executed, the changed set value is not written in to the non-volatile memory and becomes valid. Use this command when temporarily changing the set value of a parameter because the value is eliminated and returned to its original value when the power supply is turned off.

Register numbers 0900H and 0910H are exclusive for writing. If either of these registers display "Incorrect fault No.", error code 02H occurs.

### ■ Error Codes

A list of MEMOBUS/Modbus errors appears below.

When an error occurs, remove the cause of the error and restart communications.

Error Code	Error Name
	Cause
01H	Function Code Error
	<ul style="list-style-type: none"> <li>Attempted to set a function code from a PLC other than 03H, 08H, and 10H.</li> </ul>
02H	Register Number Error
	<ul style="list-style-type: none"> <li>None of the register numbers exist.</li> <li>Attempted to send a broadcast message that did not start with 0001H or 0002H.</li> </ul>
03H	Invalid Number of Registers/Bit Count Error
	<ul style="list-style-type: none"> <li>Read data or write data is greater than 16 bits.</li> <li>Invalid command message quantity. In a write message, the "Number of Data Items" contained within the message must equal twice the amount of data words (i.e., the total of Data 1+ Data 2, etc.).</li> </ul>
21H	Data Setting Error
	<ul style="list-style-type: none"> <li>Control data or parameter write data is outside the allowable setting range.</li> <li>Attempted to write a contradictory parameter setting.</li> </ul>
22H	Write Mode Error
	<ul style="list-style-type: none"> <li>Attempted to write while the drive was operating to a parameter that cannot be written to during run.</li> <li>During an EEPROM data error (CPF06), the PLC attempted to write to a parameter other than A1-00 to -05, E1-03, or o2-04.</li> <li>Attempted to write to read-only data.</li> </ul>
23H	DC Bus Undervoltage Write Error
	<ul style="list-style-type: none"> <li>Attempted to write from the PLC during an undervoltage fault (Uv1).</li> <li>Attempted to execute and Enter command from the PLC during Uv1.</li> </ul>
24H	Write Error During Parameter Process
	<ul style="list-style-type: none"> <li>PLC attempted writing to the drive while the drive was processing parameter data.</li> </ul>

## 10 Specifications

### ◆ Specifications

**Table 24 Option Unit Specifications**

Model	SI-P3/V (PCB model: SI-P3)
PROFIBUS-DP Data	PROFIBUS DP-V0, V1 PPO TYPE: 1~5 (No. 3.072, Profile for Variable Speed Drives) Extended data 1 High-speed I/O data (inputs: 16 bytes, outputs: 16 bytes) MEMOBUS/Modbus message (inputs: 16 bytes, outputs: 16 bytes) Extended data 2 High-speed I/O data (inputs: 4 bytes, outputs: 4 bytes) MEMOBUS/Modbus message (inputs: 8 bytes, outputs: 8 bytes) Basic data High-speed I/O data (inputs: 6 bytes, outputs: 6 bytes)
Connector	9-pin D-SUB connector (#4/40 UNC thread)
Communications Speed	9.6 kbps to 12 Mbps
Ambient Temperature	-10 °C to +50 °C
Humidity	up to 95% RH (no condensation)
Storage Temperature	-20 °C to +60 °C (allowed for short-term transport of the product)
Area of Use	Indoor (free of corrosive gas, airborne particles, etc.)
Altitude	up to 1000 m

### ◆ Revision History

The revision dates and the numbers of the revised manuals appear on the bottom of the back cover.

MANUAL NO. SIEP C730600 23A

Printed in Japan July 2007 07-7

Date of  
printing

Date of original  
publication

Date of Printing	Revision Number	Section	Revised Content
July 2007	-	-	First Edition

# YASKAWA AC Drive-V1000 Option

# PROFIBUS-DP

# Technical Manual

---

#### **IRUMA BUSINESS CENTER (SOLUTION CENTER)**

480, Kamifujisawa, Iruma, Saitama 358-8555, Japan  
Phone 81-4-2962-5696 Fax 81-4-2962-6138

#### **YASKAWA ELECTRIC AMERICA, INC.**

2121 Norman Drive South, Waukegan, IL 60085, U.S.A.  
Phone 1-847-887-7000 Fax 1-847-887-7370

#### **YASKAWA ELÉTRICO DO BRASIL LTDA.**

Avenida Fagundes Filho, 620 Bairro Saude-Sao Paulo-SP, Brazil CEP: 04304-000  
Phone 55-11-5071-2552 Fax 55-11-5581-8795

#### **YASKAWA ELECTRIC EUROPE GmbH**

Am Kronberger Hang 2, 65824 Schwalbach, Germany  
Phone 49-6196-569-300 Fax 49-6196-569-312

#### **YASKAWA ELECTRIC UK LTD.**

1 Hunt Hill Orchardton Woods Cumbernauld, G68 9LF, United Kingdom  
Phone 44-1236-735000 Fax 44-1236-458182

#### **YASKAWA ELECTRIC KOREA CORPORATION**

7F, Doore Bldg. 24, Yeoido-dong, Youngdungpo-Ku, Seoul 150-877, Korea  
Phone 82-2-784-7844 Fax 82-2-784-8495

#### **YASKAWA ELECTRIC (SINGAPORE) PTE. LTD.**

151 Lorong Chuan, #04-01, New Tech Park 556741, Singapore  
Phone 65-6282-3003 Fax 65-6289-3003

#### **YASKAWA ELECTRIC (SHANGHAI) CO., LTD.**

No.18 Xizang Zhong Road, Room 1702-1707, Harbour Ring Plaza Shanghai 200001, China  
Phone 86-21-5385-2200 Fax 86-21-5385-3299

#### **YASKAWA ELECTRIC (SHANGHAI) CO., LTD. BEIJING OFFICE**

Room 1011A, Tower W3 Oriental Plaza, No.1 East Chang An Ave.,  
Dong Cheng District, Beijing 100738, China  
Phone 86-10-8518-4086 Fax 86-10-8518-4082

#### **YASKAWA ELECTRIC TAIWAN CORPORATION**

9F, 16, Nanking E. Rd., Sec. 3, Taipei, Taiwan  
Phone 886-2-2502-5003 Fax 886-2-2505-1280



YASKAWA

#### **YASKAWA ELECTRIC CORPORATION**

In the event that the end user of this product is to be the military and said product is to be employed in any weapons systems or the manufacture thereof, the export will fall under the relevant regulations as stipulated in the Foreign Exchange and Foreign Trade Regulations. Therefore, be sure to follow all procedures and submit all relevant documentation according to any and all rules, regulations and laws that may apply.

Specifications are subject to change without notice for ongoing product modifications and improvements.

© 2007 YASKAWA ELECTRIC CORPORATION. All rights reserved.

MANUAL NO. SIEP C730600 23A

Printed in Japan July 2007 07-7

07-7①